

SECTION A-A

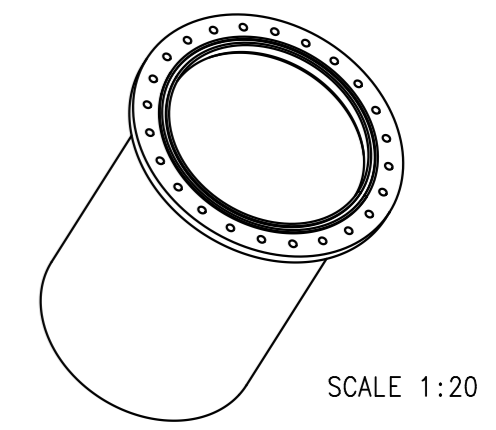

SCALE 1:20

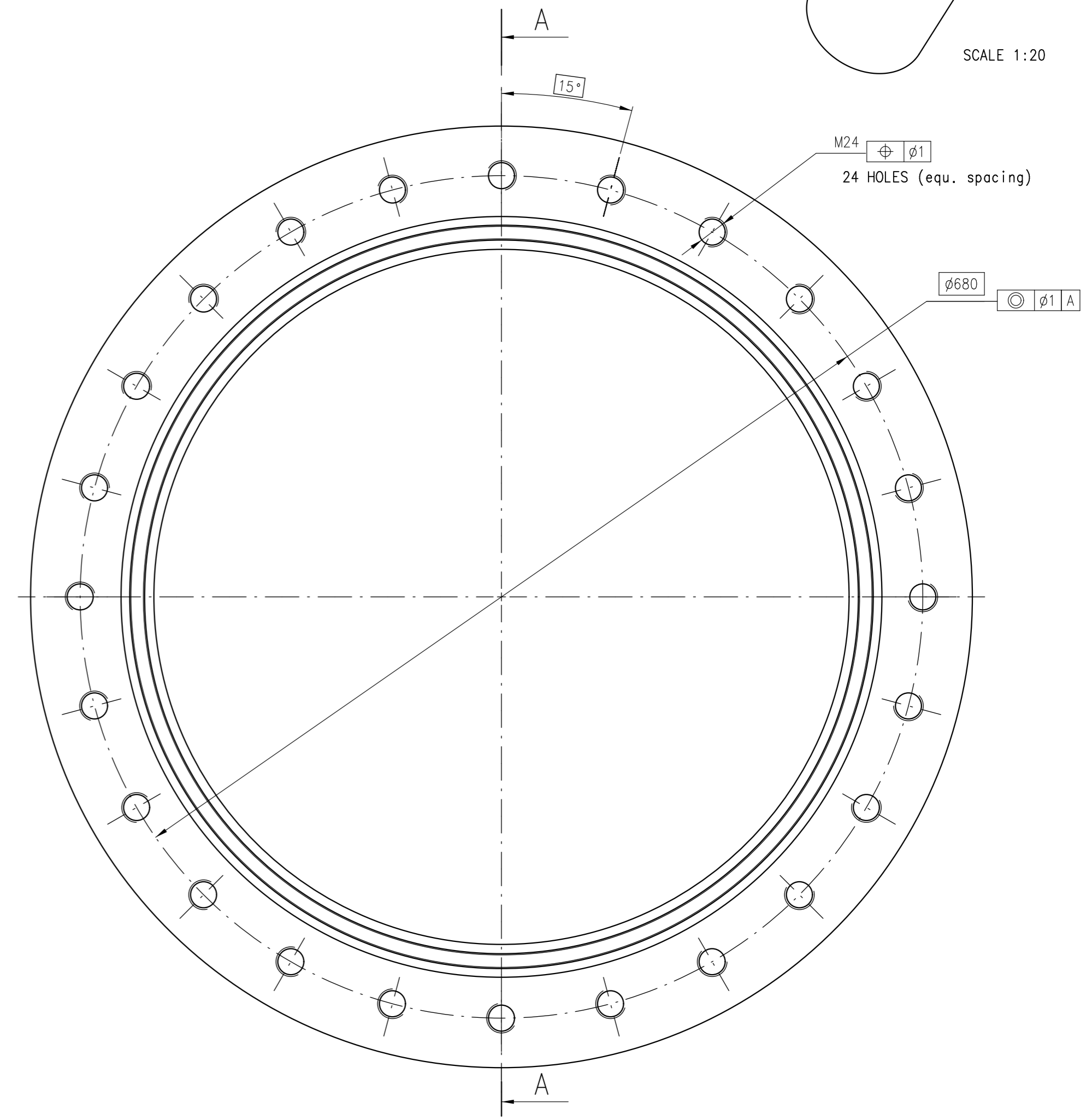

DEBURRED

NOTE: To be delivered with material certificate 3.1.B EN10204  
 Approval Test Certificate for Welding Operator NS-EN 1418,  
 Welder Approval Test Certificate NS-EN 287  
 Welding Procedure Specification (WPS) NS-EN 288-3  
 Welding Rod approved by Classification Society.

Surface Treatment: Iron Oxide Primer 20-40 micron.

Approved By DnV.

|                      |            |              |  |
|----------------------|------------|--------------|--|
| 2                    | 1          | FLANGE:35    | Material: S355J2+N (St52-3N) EN10025                               |
| 1                    | 1          | TUBE:ø610x20 | DIN 17121, Material: S355J2H (St52-3N) EN10025                     |
| REV /SIGN            | B          | bøj          | C bøj  |
| DATE                 | 2008.09.02 | 2012.09.17   |  |
| PROJ. METHOD         |            |              | UNLESS OTHERWISE STATED, TOLERANCE DIM: ISO 2768-mK THREAD: 6g /6H |
| SCALE                | 1:3        | 1:1          | 1:20   |
| DRAWN                | 2003.01.22 | bøj          |  |
| CHECKED              | 2003.01.30 | OS           |  |
| APPROVED             | 2003.01.30 | SJ           |  |
| Sonar Mounting Trunk |            |              | PARTS LIST   |
| Sonar SP92 / SP93    |            |              | 871-207481   |
| SHEET 1 OF 1         |            |              | SH. SIZE: A2   |
| FILE NO:             |            |              | REV: C   |
|                      |            |              | 3D   |



A KONGSBERG Company