

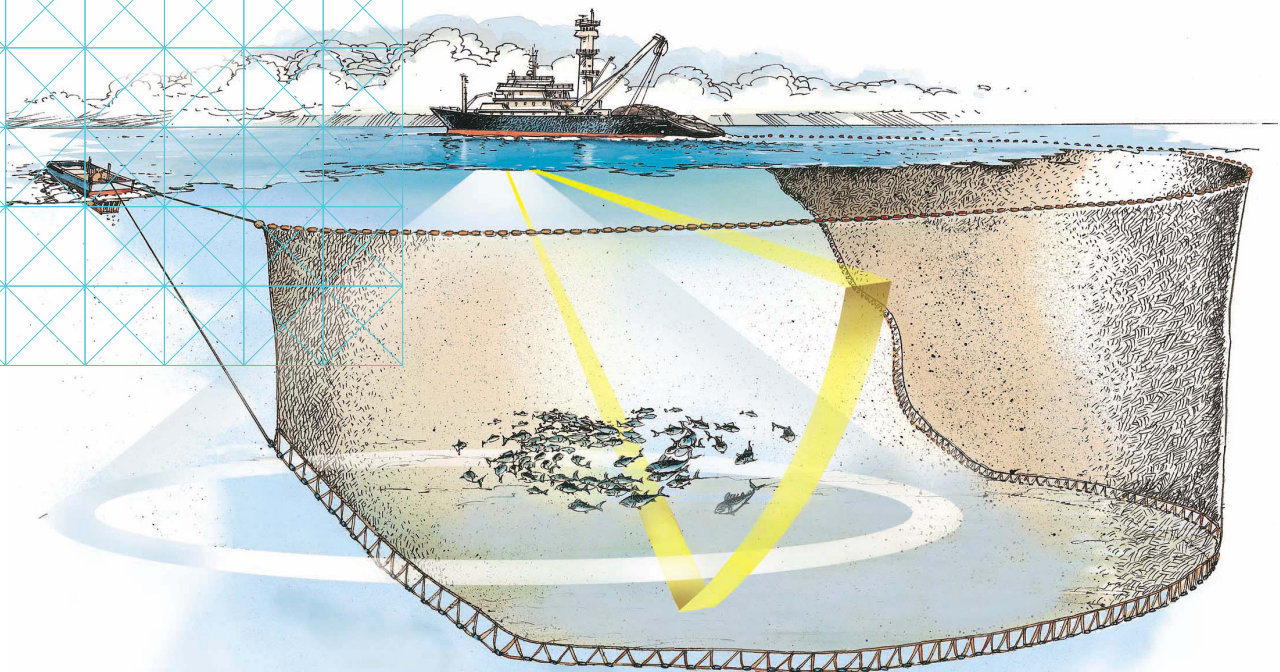

KONGSBERG

TECHNICAL SPECIFICATIONS

Simrad SX90





Simrad SX90

Fish-finding sonar

Technical specifications

The purpose of this publication is to present the technical specifications related to the Simrad SX90 system. These technical specifications summarize the main functional and operational characteristics of the SX90 Fish-finding sonar. They also provide information related to power requirements, physical properties and environmental conditions.

At Kongsberg Maritime, we are continuously working to improve the quality and performance of our products. The technical specifications may be changed without prior notice.

Caution

You must never permit the SX90 system to transmit (ping) when the ship is in a dry dock. The transducer can be damaged if it transmits in the open air.

Additional end-user documents related to the SX90 system can be found on our website. This includes publications that are translated into other languages. Selected publications are also provided in IETM (*Interactive Electronic Technical Manual*) formats.

- <https://www.kongsberg.com/sx90>

SIMRAD
By KONGSBERG

Document information

- **Product:** Simrad SX90
- **Document:** Technical specifications
- **Document part number:** 386618
- **Revision:** B
- **Date of issue:** 17 April 2023

Copyright

The information contained in this document remains the sole property of Kongsberg Maritime AS. No part of this document may be copied or reproduced in any form or by any means, and the information contained within it is not to be communicated to a third party, without the prior written consent of Kongsberg Maritime AS.

Warning

The equipment to which this manual applies must only be used for the purpose for which it was designed. Improper use or maintenance may cause damage to the equipment and/or injury to personnel. You must be familiar with the contents of the appropriate manuals before attempting to operate or work on the equipment.

Kongsberg Maritime disclaims any responsibility for damage or injury caused by improper installation, use or maintenance of the equipment.

Disclaimer

Kongsberg Maritime AS endeavours to ensure that all information in this document is correct and fairly stated, but does not accept liability for any errors or omissions.

Support information

If you require maintenance or repair, contact your local dealer. You can also contact us using the following address: simrad.support@simrad.com. If you need information about our other products, visit <https://www.kongsberg.com/simrad>. On this website you will also find a list of our dealers and distributors.

Table of contents

SIMRAD SX90	7
Important.....	8
System description.....	10
System diagram.....	12
System units.....	13
Display description.....	13
Processor Unit description.....	14
Transceiver Unit description	15
Hull Unit description	16
Transducer description	17
Installation trunk description.....	18
Additional required and optional items.....	20
Installation trunk requirement	20
Speed log requirement.....	21
Course gyro requirement	21
Uninterruptible power supply (UPS) requirement	21
Operating Panel option.....	22
Global positioning system (GPS) option.....	22
Scope of supply.....	23
Order information	24
General safety rules.....	25
Installation requirements.....	27
Supply voltage requirements	27
Uninterruptible power supply (UPS) requirements.....	27
Cables and wiring requirements	28
Compass deviation requirements.....	28
Noise sources.....	28
Dry docking requirements	29
Requirement for classification approval.....	29
Network security.....	29
Support information	30
TECHNICAL SPECIFICATIONS.....	33
Introduction to technical specifications	34
Performance specifications	34
Power requirements	38
Display power requirements.....	38
Operating Panel power requirements (Mk1)	38

Operating Panel power requirements (Mk2)	39
Operating Panel power requirements (Mk3)	39
Transceiver Unit power requirements	39
Hull Unit power requirements	40
Weights and outline dimensions	41
Display weight and outline dimensions.....	41
Enix Processor Unit weight and outline dimensions.....	41
Operating Panel weight and outline dimensions (Mk1).....	42
Operating Panel weight and outline dimensions (Mk2).....	42
Operating Panel weight and outline dimensions (Mk3).....	42
Transceiver Unit weight and outline dimensions	43
Hull Unit weight and outline dimensions.....	43
Environmental requirements.....	45
Display environmental requirements.....	45
Enix Processor Unit environmental requirements.....	45
Operating Panel environmental requirements (Mk1).....	46
Operating Panel environmental requirements (Mk2).....	46
Operating Panel environmental requirements (Mk3).....	46
Transceiver Unit environmental requirements	47
Hull Unit environmental requirements.....	47
Compass safe distance	48
Display compass safe distance	48
Processor Unit compass safe distance	48
Operating Panel compass safe distance (Mk1).....	48
Operating Panel compass safe distance (Mk2).....	49
Operating Panel compass safe distance (Mk3).....	49
Transceiver Unit compass safe distance.....	49
Hull Unit compass safe distance	49
Minimum display requirements	50
DRAWING FILE.....	51
About the drawings in the drawing file.....	52
385609 Processor Unit outline dimensions Enix.....	53
494024 Processor Unit outline dimensions (HT20470/DC).....	57
494025 Processor Unit outline dimensions (HT20470/AC).....	60
204688 Operating Panel dimensions (Mk1)	63
443179 Operating Panel dimensions (Mk2)	65
440689 Operating Panel cut-out drawing (Mk2).....	68
439594 Operating Panel adapter plate (Mk2).....	69
476352 Operating Panel dimensions (Mk3)	71
110-0003426 Transceiver dimensions (Mk2)	74

328873 Transceiver dimensions (Mk1/Old)	77
280328 Hull Unit dimensions SX92	80
280328 Hull Unit dimensions SX93	83
318900 Hull Unit dimensions SX95	86
207481 Installation trunk dimensions SX92/SX93	89
322202 Installation trunk dimensions SX95	91
113361 Installation trunk SX95	92
207485 Blind flange dimensions (ø760 mm)	94
113362 Blind flange dimensions (ø580 mm)	95
082973 Mounting flange DN500	96
083045 Gate valve installation DN500	99
33498 Gate valve dimensions DN500	101
37357 Gate valve dimensions DN500	104
DATAGRAM FORMATS	107

Simrad SX90

Topics

- [Important, page 8](#)
- [System description, page 10](#)
- [System diagram, page 12](#)
- [System units, page 13](#)
- [Additional required and optional items, page 20](#)
- [Scope of supply, page 23](#)
- [Order information, page 24](#)
- [General safety rules, page 25](#)
- [Installation requirements, page 27](#)
- [Network security, page 29](#)
- [Support information, page 30](#)

Important

The SX90 is an advanced product. It is used with other advanced products. There is important information that you need to know.

Watertight integrity

The size, location and design of the sonar room must fulfil all the requirements to the vessel's watertight integrity.

In the event of a major leak, it must be possible to close all watertight hatches and/or doors to the room to maintain vessel stability and safety. The physical size of the sonar room must be limited, so that in the event of a major leak, the flooding of the room will not induce instability, or cause the vessel to capsize or sink.

For more information, see *Sonar room requirements*.

Mechanical support of the installation trunk

The installation trunk must be secured to the bulkheads and/or the hull by means of strengthening plates (stiffereners). The dimensions and strength of the plates must be adequate to prevent any vibrations. This is an invariable requirement to ensure the safety of the SX90 system and the vessel.

The shape and locations of the strengthening plates must be determined by the installation shipyard based on the physical properties of the installation trunk, the hull and the space available. Minimum four strengthening plates must be used. Each strengthening plate must extend all the way from the bottom to the top of the installation trunk. Only leave a small gap to allow access to the bolts and nuts used to secure the mounting flange. The minimum plate thickness is 10 mm, but the classification society can specify other dimensions.

Mechanical support of the hull unit gantry

The hull unit gantry must be secured to the bulkhead by means of mechanical support brackets. The dimensions and strength of the support brackets must be adequate to prevent vortex induced vibrations. This is an invariable requirement to ensure the safety of the SX90 system and the vessel.

We recommend that support brackets are placed pointing at minimum three directions with approximately 120 degrees between them.

The mechanical support brackets must be designed and manufactured by the installation shipyard to fit the complete installation in the sonar room. All calculations made to support the design must meet the applicable safety requirements, and apply to the physical properties of the complete installation.

Before you turn on the SX90 system

Before you turn on the SX90 system, make sure that you have sufficient water depth to lower the transducer!

Caution

You must never turn on the SX90 system when the ship is in dry dock. The transducer can be damaged if it transmits in the open air.

When the SX90 system is not used

When you do not use the SX90 system, turn it off.

Note

You must never turn off the SX90 system by means of the on/off switch on the Processor Unit. You must ALWAYS use the Operating Panel.

When you are docking your vessel

You must never set the SX90 system to normal operation when the ship is in dry dock. The transducer can be damaged if it transmits in the open air. To prevent inadvertent use of the SX90 system, pull out the mains plug on the Processor Unit whenever your vessel is in dry dock. Additional precautionary measures should be considered.

If something breaks down

If you believe that something has broken down, contact your local dealer. A list of all our dealers is provided on our website.

- <https://www.kongsberg.com/sx90>

If you are unable to contact a dealer, observe the support information in this publication.

When you want to turn off the SX90 system

You must never turn off the SX90 system by means of the on/off switch on the Processor Unit. When you do not use the SX90 system, turn it off with the **Power** button on the Operating Panel. If the transducer is lowered when you turn off the SX90 system, it is automatically retracted to its upper position.

Note

If you turn off the SX90 system by means of the on/off switch on the Processor Unit you can damage the software and the interface settings used to communicate with external devices.

Manual operation of the hull unit

In the event of improper operation, the powerful electric motor on the hull unit may cause serious damage to the equipment and/or injury to personnel. Therefore, before you start manual operation, read carefully through the relevant operating procedures.

Note

You must familiarize yourself with the correct handling methods and the relevant safety requirements.

Rules for transducer handling

A transducer must always be handled as a delicate instrument. Incorrect actions may damage the transducer beyond repair. A physical blow to the transducer face may easily damage one or more elements. Observe these transducer handling rules:

- **Do not** activate the transducer when it is out of the water.
- **Do not** handle the transducer roughly. Avoid impacts.
- **Do not** expose the transducer to direct sunlight or excessive heat.
- **Do not** use high-pressure water, sandblasting, metal tools or strong solvents to clean the transducer.
- **Do not** damage the outer protective skin of the transducer.
- **Do not** step on the transducer cables.
- **Do not** damage the transducer cables. Avoid exposure to sharp objects.

System description

The SX90 is a long range omnidirectional low frequency sonar. The SX90 system is designed for medium and large sized fishing vessels. It was originally developed for purse seiners, but experience has proven that it is also well suitable for trawlers.

The SX90 system is designed for fishing vessels of all sizes, both purse seiners and trawlers. The centre operational frequency is 26 kHz. You can select any operational frequency from 20 to 30 kHz. The cylindrical multi-element transducer allows the omnidirectional sonar beams to be tilted electronically. This allows you to automatically track schools of fish, and to observe the whole water volume around the vessel. A stabilizing system is included for electronic pitch and roll compensation.

The SX90 system offers a number of standard interface lines for communication with peripheral devices and sensors. Typical inputs are geographical information from a positioning system, vessel speed and current heading. By default, the SX90 system uses a built-in motion sensor. For improved operational accuracy, an external motion reference unit (MRU) can be connected.

The SX90 system offers the same user interface and operating software as our other sonars, echo sounders and catch monitoring systems. This enables easier and faster training of new users.

- The echo presentations are optimised for multiple displays. Provided that you have connected additional displays to your Processor Unit, you can use the **Docking Views**

function to take any sonar view and place it on a separate display. When you move a view to another display, it will automatically be scaled for the best possible result.

- It is common for sonars to require many pings to build the various views in the echo presentation. On the SX90, all the sonar views in the presentation are built using the echoes from one single ping. This dramatically improves the update rate and provides better real-time information.
- The SX90 system permits you to record real-time sonar situations. This allows you to replay complete sequences. The playback contains the exact same echo information, and can be used for mission history, training or troubleshooting purposes.

Great emphasis has been placed on an intuitive user interface and the best possible sonar presentations on a high resolution colour display.

The SX90 system is equipped with the celebrated signal processing software developed by Kongsberg Maritime. This includes Hyperbolic FM (HFM) transmissions. This pulse type is also known as "chirp". It ensures a clutter free picture with very high resolution in range. The signal processing and beamforming is performed in a fast digital signal processing system using the full dynamic range of the signals.

The SX90 system software operates using the Microsoft® Windows® operating system.

System diagram

The system diagram identifies the main components of a basic SX90 system. Only the main connections between the units are shown. Detailed interface capabilities and power cables are not shown.

- A *Display (The second display is optional.)*
- B *Processor Unit*
- C *Operating Panel*
- D *Transceiver Unit*
- E *Hull Unit*
- F *Hoisting motor*
- G *Motor Control Unit*
- H *Transducer*

In this publication, the computer can also be referred to as the *Processor Unit*, and vice versa.

Unless otherwise specified in a contract, the display is not included in the standard delivery. This is a commercial item that can be purchased locally.

A choice of hull units is available for the SX90 system. The hull units offer different physical properties and lowering depths. The same transducer is used on all hull unit types. Different installation trunks are used on the various hull unit types.

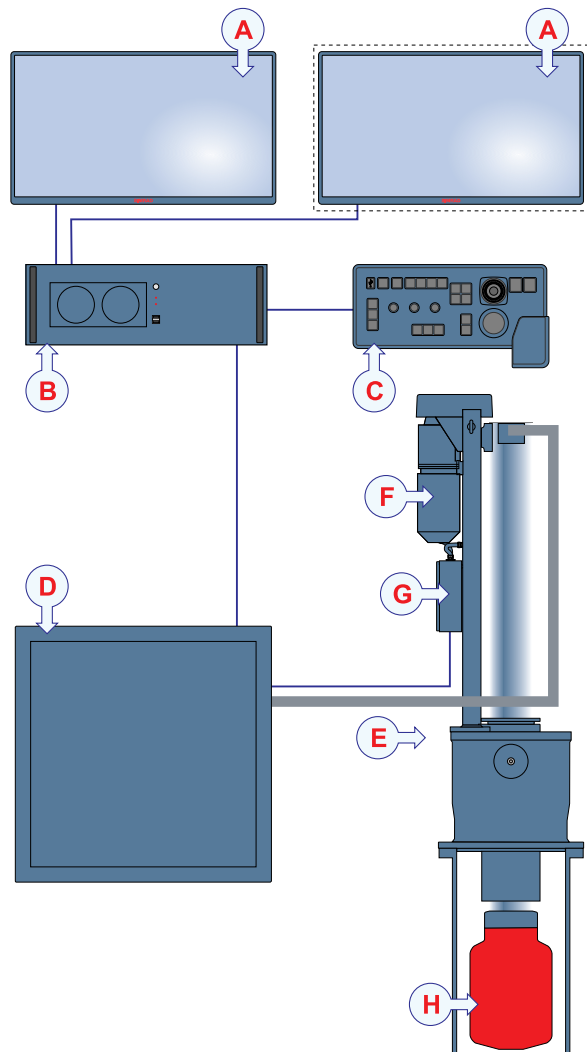

System units

Topics

[Display description, page 13](#)

[Processor Unit description, page 14](#)

[Transceiver Unit description, page 15](#)

[Hull Unit description, page 16](#)

[Transducer description, page 17](#)

[Installation trunk description, page 18](#)

Display description

A display is a required part of the SX90 system. For best readability, the display must be protected from glare and have the correct height and angle.

Any commercial display can be used with the SX90 system, provided that the chosen display meets the minimum requirements.

Tip

You may find it useful to have more than one display connected to the SX90 system. The number of displays must be chosen to fit the preferences of the crew.

The display is not a standard part of the delivery. This is a commercial item that can be purchased locally. Kongsberg Maritime may provide a suitable display. The chosen display must be designed for maritime use, and it must meet the minimum performance specifications. The video interface must match the output format(s) provided by the Processor Unit.

Related topics

[Simrad SX90, page 7](#)

[System units, page 13](#)

Processor Unit description

A dedicated maritime computer is provided. In this publication, the computer can also be referred to as the *Processor Unit*, and vice versa.

The Processor Unit is a rugged and powerful computer. It is designed for long life in a demanding maritime environment. The Processor Unit contains the operational software, and offers the user interface that allows you to control the SX90 system. Furthermore, it offers a number of serial and Ethernet lines for communication with external devices. The Processor Unit is normally mounted on the bridge.



The HT20470 Processor Unit is available in two versions. The DC version operates on +24 VDC while the AC version operates on 100 to 240 VAC.

Power supply:

- **Manufacturer:** Mean Well
- **Manufacturer's website:** <https://www.meanwell.com>
- **Type designation:** SDR-240-24
- **Kongsberg Maritime part number:** 488156

Note

The Processor Unit does not contain any fans. It will be very warm, even during normal operation. This is by design. Airflow around the unit will significantly increase the effect of the heat sinks and thereby also the lifetime of the unit. Such an air flow is highly recommended. The computer has been tested and verified with ambient temperatures up to 50 degrees Celsius. A lower ambient temperature is however positive for the its lifetime.

Note

The Processor Unit does not contain any fans. It will be very warm, even during normal operation. This is by design.

Related topics

[Simrad SX90, page 7](#)

[System units, page 13](#)

Transceiver Unit description

The Transceiver Unit is provided to transmit acoustic energy through water. After each transmission, the transceiver receives the echoes from the seabed and/or the water column. These echoes are filtered, amplified and finally converted into digital format. This transmission and reception sequence is commonly referred to as a *ping*.

The Transceiver Unit is normally located in the sonar room. It is mounted on the bulkhead using powerful shock absorbers. The physical distance to the hull unit is limited by the length of the transducer cables.

The transceiver controls the transmission and reception made by the transmitters and receiver channels. 8 identical transceiver boards are used. These transceiver boards provide 256 individual transmit- and receiver channels. The Transceiver Unit also holds an Ethernet switch and a large capacitor bank. An internal power supply is provided to supply the required DC voltages to the Transceiver Unit.

A high quality Ethernet cable is used for communication with the Processor Unit on the bridge. Another high quality Ethernet cable is used to connect the Transceiver Unit to the Motor Control Unit on the hull unit.

It is very important that high-quality Ethernet cables are used. Do not make the connection using the existing local area network (LAN).

Tip

We recommend that you install an extra Ethernet cable between the Transceiver Unit and the Processor Unit.

The transducer cables are plugged into the side wall of the transceiver cabinet using a special connector. The connectors for power and interfaces are located at the bottom of the cabinet.

Note

To extend the lifetime of the Transceiver Unit, it must be mounted at dry and clean location with sufficient ventilation. Observe the sonar room requirements

The Transceiver Unit can be fitted with a commercial heat exchanger. The purpose of the heat exchanger is to provide a stable, clean and temperature controlled environment for the electronic circuitry inside the Transceiver Unit. The heat exchanger also inhibits dust and dirt particles from entering the transceiver. The heat exchanger is powered from 230 VAC using a separate outlet.

Related topics

[Simrad SX90, page 7](#)

[System units, page 13](#)

Hull Unit description

The hull unit is used to lower the transducer down below the ship's hull when the SX90 system shall be used. When the SX90 system is turned off, the transducer is hoisted for protection. The hull unit is large and crucial part of the sonar system.

The hull unit is a mechanical construction. It is mounted on the top of the installation trunk. The installation trunk penetrates the ship's hull, and allows the transducer to be lowered into the sea. The hull unit is normally located in the forward part of the vessel. This location is recommended to avoid the noise from the propellers and the engine.

Caution

When the transducer is lowered, the depth of water under the vessel must be monitored closely.

If the transducer hits larger objects or bottom, the transducer shaft may be bent, or - in worst case - it can be broken off. A broken transducer shaft will cause water leakage through the top of the shaft. If you suspect that the transducer shaft is seriously damaged with holes, do not retract the transducer to its upper position.

To prevent serious damage to the vessel or the vessel stability, you must have a water pump and a warning system in the sonar room.

If you forget to hoist the transducer before the SX90 system is turned off, the transducer is hoisted automatically before the power is disconnected. The transducer is also hoisted automatically if a serious malfunction occurs to the communication between the bridge and the hull unit.

In the event of improper operation, the powerful electric motor on the hull unit may cause serious damage to the equipment and/or injury to personnel. Therefore, before you start manual operation, read carefully through the relevant operating procedures. You must familiarize yourself with the correct handling methods and the relevant safety requirements.

The SX90 system can be provided with one of the following hull units:

Hull Unit	Lowering depth (m)	Transducer cable (m)	Maximum speed (knots)
SX92	1.2	4.6	25
SX93	1.6	4.6	20
SX95	1.0	4.6	12
The same transducer is used on all hull unit types.			

On some vessels, additional transducer protection is required. One example is vessels working in arctic conditions. It is important for them to prevent ice from damaging the transducer. A gate valve is then added to the hull unit installation. By means of a mechanical construction it shuts off the bottom of the installation trunk when the SX90 system is not used.

For more information, refer to the end-user documentation provided by the manufacturer.

Important

The hull unit gantry must be secured to the bulkhead by means of mechanical support brackets. The dimensions and strength of the support brackets must be adequate to prevent vortex induced vibrations. This is an invariable requirement to ensure the safety of the SX90 system and the vessel.

We recommend that support brackets are placed pointing at minimum three directions with approximately 120 degrees between them.

The mechanical support brackets must be designed and manufactured by the installation shipyard to fit the complete installation in the sonar room. All calculations made to support the design must meet the applicable safety requirements, and apply to the physical properties of the complete installation.

Related topics

[Simrad SX90, page 7](#)

[System units, page 13](#)

Transducer description

The cylindrical transducer allows the sonar beam to provide a full 360 degrees coverage of the water volume.

The transducer converts the electric energy generated by the transmitter circuitry to physical vibrations. These vibrations alter the water pressure, and create an acoustic pulse that is sent into the water. The acoustic signal is transmitted as a beam. The duration of the acoustic pulse, as well as its frequency and shape, are controlled by the system software. The direction and opening angle of the beam is controlled by the transmitter circuitry and the physical properties of the transducer. After the transmission, the transducer works as a "microphone". It converts the water pressure created by the acoustic echoes to electric energy. These weak echo signals are sent to the amplifiers in the receiver circuitry.

Note

The transducer is covered with a thick red or black protective coating made of a special plastic type. The protective coating is a vital part of the transducer. It is very important that neither this coating nor the internal parts of the transducer are damaged during the handling, installation or cleaning. Any holes and/or scratches in the transducer surface will allow water to penetrate the transducer. If a leak occurs, the transducer must be replaced.

- A** Lower part of shaft sleeve
- B** Lower part of transducer shaft
- C** Transducer with its red protective coating

The transducer is mounted at the bottom end of the hull unit's transducer shaft. This allows the transducer to be lowered into the water for operational use, and retracted for protection when the SX90 system is turned off. By lowering the transducer into the water, you may also be able to reduce the noise created by the laminar flow of water along the hull.

The transducer is large and heavy. It contains 256 individual elements.

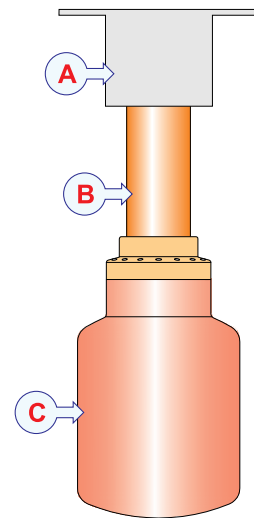

Rules for transducer handling

A transducer must always be handled as a delicate instrument. Incorrect actions may damage the transducer beyond repair. A physical blow to the transducer face may easily damage one or more elements. Observe these transducer handling rules:

- **Do not** activate the transducer when it is out of the water.
- **Do not** handle the transducer roughly. Avoid impacts.
- **Do not** expose the transducer to direct sunlight or excessive heat.
- **Do not** use high-pressure water, sandblasting, metal tools or strong solvents to clean the transducer.
- **Do not** damage the outer protective skin of the transducer.
- **Do not** step on the transducer cables.
- **Do not** damage the transducer cables. Avoid exposure to sharp objects.

Related topics

[Simrad SX90, page 7](#)

[System units, page 13](#)

Installation trunk description

An installation trunk is required for hull unit installation. The installation trunk is not included in the standard delivery.

The installation trunk provides the physical foundation for the entire hull unit. The installation trunk penetrates the hull. The installation trunk is therefore a crucial part of the hull unit assembly. In order to ensure proper operation of the SX90 system, the physical location of the installation trunk must be carefully selected.

The installation trunk - with a blind flange - can be ordered from Kongsberg Maritime as an optional delivery. As an alternative, the installation trunk can be manufactured by the

shipyard based on the drawings in this manual. A locally manufactured installation trunk can be adjusted to better fit the properties of the vessel's hull.

Note

If the installation trunk is manufactured locally, the installation shipyard is responsible for obtaining the approval certificates from the relevant national registry.

The installation trunk is not used when a gate valve is mounted. The installation trunk is then replaced with a transducer dock.

Due to the different flange diameters, different installation trunks are used.

Installation trunk	Upper diameter (mm)	Bottom diameter (mm)	Part number	Drawing	Blind flange
SX92	760	610	SP9-207516	871-207481	499-205560
SX93	760	610	SP9-207516	871-207481	499-207506
SX95	580	508	SQ4-042508	830-113361	830-113362

Each installation trunk is provided with an O-ring or a gasket for use between the hull unit flange and the top of the installation trunk (or transducer dock). Relevant mounting hardware (bolts, nuts and washers) are also included. A blind flange is included to protect the top of the installation trunk prior to hull unit installation.

Important

The installation trunk must be secured to the bulkheads and/or the hull by means of strengthening plates (stiffereners). The dimensions and strength of the plates must be adequate to prevent any vibrations. This is an invariable requirement to ensure the safety of the SX90 system and the vessel.

The shape and locations of the strengthening plates must be determined by the installation shipyard based on the physical properties of the installation trunk, the hull and the space available. Minimum four strengthening plates must be used. Each strengthening plate must extend all the way from the bottom to the top of the installation trunk. Only leave a small gap to allow access to the bolts and nuts used to secure the mounting flange. The minimum plate thickness is 10 mm, but the classification society can specify other dimensions.

Related topics

[Simrad SX90, page 7](#)

[System units, page 13](#)

Additional required and optional items

Topics

[Installation trunk requirement, page 20](#)

[Speed log requirement, page 21](#)

[Course gyro requirement, page 21](#)

[Uninterruptible power supply \(UPS\) requirement, page 21](#)

[Operating Panel option, page 22](#)

[Global positioning system \(GPS\) option, page 22](#)

Installation trunk requirement

An installation trunk is required for hull unit installation. The installation trunk is not included in the standard delivery.

The installation trunk provides the physical foundation for the entire hull unit. The installation trunk penetrates the hull. The installation trunk is therefore a crucial part of the hull unit assembly. In order to ensure proper operation of the SX90 system, the physical location of the installation trunk must be carefully selected.

The installation trunk - with a blind flange - can be ordered from Kongsberg Maritime as an optional delivery. As an alternative, the installation trunk can be manufactured by the shipyard based on the drawings in this manual. A locally manufactured installation trunk can be adjusted to better fit the properties of the vessel's hull.

Note

If the installation trunk is manufactured locally, the installation shipyard is responsible for obtaining the approval certificates from the relevant national registry.

The installation trunk is not used when a gate valve is mounted. The installation trunk is then replaced with a transducer dock.

Speed log requirement

In order to operate correctly, the SX90 system requires input from a speed log. Unless specified in the contract, a speed log is not a part of the SX90 system delivery. Provided that a speed log sensor is interfaced to the SX90 system, the vessel's current speed can be presented in the user interface.

Note

Without speed information, the SX90 system will neither be able to present correct navigational information, nor compensate for vessel movements. This lack of compensation will prevent the system from providing correct echo information.

In most cases a suitable sensor is already installed on the vessel. A global positioning system (GPS) with a compatible output format can also be used.

Course gyro requirement

In order to operate correctly, the SX90 system requires input from a course gyro. A course gyro is not a part of the SX90 delivery. When a course gyro is connected to the SX90, the vessel's current heading can be presented in the user interface.

Without the input from a course gyro, the SX90 system will not be able to present correct navigational information. In most cases a suitable course gyro is already installed on the vessel.

Note

Most global positioning system (GPS) can provide course information, but this data is generally too inconsistent to provide a stable presentation on the SX90 system. This inconsistency is especially noticeable at low vessel speeds. Incorrect course information can then result in settings not working properly.

We recommend that you use a satellite compass or a gyro compass.

Uninterruptible power supply (UPS) requirement

It is important to ensure continuous operation of the SX90 system independent of any varying quality of the vessel's mains supply. The use of uninterruptible power supplies (UPS) is therefore required.

Uninterruptible power supply units are not included in the standard SX90 system delivery. These items must be purchased locally. Several commercial types are available.

Note

Make sure that the Uninterruptible Power Supply (UPS) does not generate switching noise in the same frequency band as the SX90 system.

To choose the best power solution for your installation, consider environmental conditions, the physical space available, the availability and duration of the batteries, and the power requirements of the SX90 system.

Operating Panel option

The optional Operating Panel contains all necessary control functions for normal operation of the SX90 system.

The controls provided by the Operating Panel are arranged in logical functional groups. This offers you clear and easy operation with fast access to key functionality. All the functionality provided by the SX90 system can be accessed using the trackball on the Operating Panel and the menu system shown in the display presentation.

The SX90 system supports three different operating panels. These are referred to as "Mk1", "Mk2" and "Mk3".

- The Mk1 Operating Panel is connected to the Processor Unit with three cables. The dual interface cable provides power and serial communication. The USB interface cable is used to read the trackball movements. The Processor Unit must be fitted with a custom made interface board. A small commercial power supply is used to provide power to the Operating Panel. (The Mk1 Operating Panel is no longer provided with new sonars. This information is provided for legacy reasons.)
- The Mk2 Operating Panel is connected to the Processor Unit using an Ethernet cable. The Operating Panel is provided with a built-in power supply.
- The Mk3 Operating Panel is connected to the Processor Unit with a USB cable. A dedicated power supply unit is not required.

Global positioning system (GPS) option

A global positioning system (GPS) may be connected to the SX90 system.

When a global positioning system (GPS) connected to the SX90 system, the vessel's current geographical position can be presented in the user interface. It will also provide latitude and longitude information for the cursor and marker(s). In addition to navigational data, the global positioning system (GPS) can also be used to provide speed information.

Note

Most global positioning system (GPS) can provide course information, but this data is generally too inconsistent to provide a stable presentation on the SX90 system. This inconsistency is especially noticeable at low vessel speeds. Incorrect course information can then result in settings not working properly.

Scope of supply

To assemble a complete SX90 system you need all the system units. The main units you need are provided with the standard delivery. Additional items are required for operation. These items must be added to the SX90 system for full operational functionality. Some items are optional. Such items can be purchased from Kongsberg Maritime or obtained locally.

Basic items

When you unpack the parts provided with the SX90 system delivery, make sure that the correct items are included. The quantity of each item is specified in the contract and/or the order confirmation. Relevant order information is provided on our website.

- <https://www.kongsberg.com/sx90>

Operational software

Operational software is provided on a suitable media.

End-user documentation

End-user documentation is provided on paper and/or digital formats. End user manuals and source drawings (normally in AutoCad format) can be downloaded from our website.

- <https://www.kongsberg.com/sx90>

Order information

To order the SX90 system, or any of the optional items provided with it, contact your local dealer. If you do not have a regular dealer, a list of all our distributors and dealers can be found on our website. Your dealer will also be able to help you with a detailed quotation including price and delivery information.

Relevant order information is provided on our website.

- <https://www.kongsberg.com/sx90>

General safety rules

Safety is important. The safety precautions must be followed at all times during installation and maintenance work.

WARNING

The SX90 system operates on 115 VAC and/or 230 VAC at 50/60 Hz. This voltage is lethal! You must never work alone on high-voltage equipment!

The hull unit is powered by a 3-phase high voltage.

This equipment must be installed, adjusted, and serviced only by qualified electrical maintenance personnel familiar with the construction and operation of the equipment and the hazards involved. Failure to observe this precaution could result in bodily injury.

Personnel requirements

All personnel must be trained in relevant installation and maintenance work.

Personal protection

Installation personnel must wear suitable work clothes. The work clothes must not contain sufficient static to ignite. Always wear a hard hat and suitable protective footwear while handling heavy objects.

Power and ground

You must always turn off all power before installation or maintenance work on the SX90 system. Use the main circuit breaker, and label the breaker with a warning sign that informs others that maintenance or installation work is in progress on the system.

For safety reasons, two persons must always be present during troubleshooting with power turned ON.

All SX90 system units must be properly grounded.

First aid

Read and understand the applicable first aid instructions related to electric shock.

Whenever installation or maintenance work is in progress, it is essential that a first aid kit is available. All personnel must be familiar with the first aid instructions for electrical shock and other personal injuries.

Weight

The various parts of the system may be heavy. Make sure that the appropriate tools and certified lifting equipment are available. Always wear a hard hat and suitable protective footwear while handling heavy objects.

Cables

Each electric cable must be handled carefully. This is important to avoid damage to the cable. This is also important to avoid electric shock in the event that the cable is unintentionally connected to a power source.

Cabinets

Do not open racks or cabinet doors while sailing in rough seas. Doors and/or cabinet parts may suddenly swing open and cause damage or injury.

Installation requirements

Topics

[Supply voltage requirements, page 27](#)

[Uninterruptible power supply \(UPS\) requirements, page 27](#)

[Cables and wiring requirements, page 28](#)

[Compass deviation requirements, page 28](#)

[Noise sources, page 28](#)

[Dry docking requirements, page 29](#)

[Requirement for classification approval, page 29](#)

Supply voltage requirements

The supply voltage must be kept within $\pm 10\%$ of the installation's nominal voltage.

Maximum transient voltage variations on the main switchboard's bus-bars must not exceed -15% to $+20\%$ of the nominal voltage (except under fault conditions).

Uninterruptible power supply (UPS) requirements

It is important to ensure continuous operation of the SX90 system independent of any varying quality of the vessel's mains supply. The use of uninterruptible power supplies (UPS) is therefore required.

Uninterruptible power supply units are not included in the standard SX90 system delivery. These items must be purchased locally. Several commercial types are available.

Note

Make sure that the Uninterruptible Power Supply (UPS) does not generate switching noise in the same frequency band as the SX90 system.

To choose the best power solution for your installation, consider environmental conditions, the physical space available, the availability and duration of the batteries, and the power requirements of the SX90 system.

Two UPS systems are required.

- 1 One UPS system is required to supply the Processor Unit and the display.
- 2 One UPS system is required to supply the Transceiver Unit.

A single UPS system is sufficient if the power capacity is provided and long cable runs are avoided.

The minimum requirements for the uninterruptible power supply (UPS) are:

- **Input voltage:** The input voltage must fit vessel supply voltage.
- **Output voltage:** 230 VAC, 50 Hz
- **Output power**
 - Processor Unit + Display: 1000 W
 - Transceiver Unit: 1500 W
- **Output form:** The output AC voltage must be a sine wave.

Cables and wiring requirements

Correct wiring is crucial for the operational performance of the SX90 system.

All cables running between system cabinets located in different rooms and/or on different decks must be supported and protected along their entire lengths using conduits and/or cable trays. Note that the cables must not be installed in the vicinity of high-power supplies and cables, antenna cables or other possible sources of interference.

Compass deviation requirements

SX90 units that are installed on the bridge may have an effect on the compass.

Once the installation is complete, the vessel must be swung with the SX90 system in both operative and inoperative modes. The shipowner and captain are responsible for updating the compass deviation table accordingly with regard to the vessel's national registry and corresponding maritime authority.

Noise sources

The operational performance of the SX90 system depends on the noise conditions. It is essential that the noise signature is as low as possible.

Vessel noise

The vessel's hull, rudder(s) and propeller(s) must be thoroughly inspected in dry dock prior to installation.

Roughness below the water-line deformities in the shell plating and protruding obstacles can create underwater noise. These sources of turbulence must be smoothed or removed as best as possible.

Note

It is especially important that the propeller(s) are not pitted or damaged.

Electrical noise

The quality of the vessel's supply power is crucial to reduce noise. Electrical or electronic self noise is picked up or generated in any other part of the equipment than the transducer. The most common source of electrical self-noise is hum. Hum is typically generated by low-quality power supplies. Cables and sensitive electronic circuitry can easily pick up hum. At higher frequencies – where rather wide bandwidths are necessary – the noise from components, transistors or other analogue electronic may be a limiting factor.

Dry docking requirements

Whenever a hull unit and an installation trunk are mounted under the vessel's hull, special considerations must be made prior to dry docking.

The location of the SX90 installation trunk must be noted on the vessel's docking plan for future reference.

Make sure that ample clearance under the SX90 installation trunk and/or blister is provided when you are placing the vessel in dry dock. Avoid locating supporting blocks or structures in the vicinity of the SX90 installation trunk.

Important

Prior to dry docking, turn off the SX90 system. If necessary, disengage the circuit breaker. Label the Processor Unit and/or the circuit breaker clearly to prevent anyone from accidentally turning on the SX90 system.

Requirement for classification approval

Classification approval is required for the SX90 system installation.

The design and mounting of the installation trunk for the SX90 system must be approved by the vessel's national registry and corresponding maritime authority and/or classification society. The shipowner and shipyard doing the installation are responsible for obtaining and paying for such approval.

Network security

If a SX90 system is connected to a local area network, data security is important.

Equipment manufactured by Kongsberg Maritime is frequently connected to the vessel's local area network (LAN). When you connect a computer to a local area network you will always expose the data on that computer. All other computers connected to the same network may be able to access your data. Several threats may immediately occur:

- Remote computers can read the data.

- Remote computers can change the data.
- Remote computers can change the behavior of the computer, for example by installing unwanted software.

Usually, two parameters are used to define the threat level:

- 1 The likelihood that any remote computer will do any of the above.
- 2 The damage done if a remote computer succeeds doing this.

Kongsberg Maritime has no information regarding the complete system installation on any vessel. Systems provided by Kongsberg Maritime are regarded as stand-alone offline systems. They are stand-alone even though they may be connected to a network for sensor interfaces and/or data distribution.

Note

No network safety applications are installed on Kongsberg Maritime computers. The computers are therefore not protected against viruses, malware or unintentional access by external users.

Securing the SX90 system itself has no meaning unless there is a policy in place that secures all computers in the network. This policy must include physical access by trained and trusted users. The customer/end user of the SX90 system will always be in charge of defining and implementing a security, policy and providing the relevant network security applications.

Note

Kongsberg Maritime will not accept any responsibility for errors and/or damages caused by unauthorized use of or access to the SX90.

Support information

If you need technical support for your SX90 system you must contact your local dealer, or one of our support offices. A list of all our offices and dealers is available on our website. You can also contact our main support office in Norway.

Norway (main office)

- **Company name:** Kongsberg Maritime AS / Simrad
- **Address:** Strandpromenaden 50, N3190 Horten, Norway
- **Telephone:** +47 33 03 40 00
- **Telefax:** +47 33 04 29 87
- **Website :** www.kongsberg.com/simrad
- **Email address:** simrad.support@simrad.com

Spain

- **Company name:** Kongsberg Maritime Spain S.L.U
- **Address:** Partida Atalayas 20, 03570 Villajoyosa, Spain
- **Telephone:** +34 966 810 149
- **Telefax:** +34 966 852 304
- **Website :** www.kongsberg.com/simrad
- **Email address:** simrad.spain@simrad.com

France

- **Company name:** Simrad France
- **Address:** 5 rue de Men Meur, 29730 Guilvinec, France
- **Telephone:** +33 298 582 388
- **Telefax:** +33 298 582 388
- **Website :** www.kongsberg.com/simrad
- **Email address:** simrad.france@simrad.com

USA

- **Company name:** Kongsberg Underwater Technology LLC (KUTL) / Simrad Fisheries
- **Address:** 19210 33rd Ave W, Suite A, Lynnwood, WA 98036, USA
- **Telephone:** +1 425 712 1136
- **Telefax:** +1 425 712 1193
- **Website :** www.kongsberg.com/simrad
- **Email address:** fish.usa.support@simrad.com

Canada

- **Company name:** Kongsberg Mesotech Ltd.
- **Address:** 1598 Kebet Way, Port Coquitlam, BC, V3C 5M5, Canada
- **Telephone:** +1 604 464 8144
- **Telefax:** +1 604 941 5423
- **Website :** www.kongsberg.com/simrad
- **Email address:** simrad.canada@simrad.com

Malaysia

- **Company name:** Kongsberg Maritime Malaysia Sdn. Bhd
- **Address:** Unit 27-5 Signature Offices, The Boulevard, Mid Valley City, Lingkaran Syed Putra, 59200 Kuala Lumpur, Malaysia

- **Telephone:** +65 6411 7488
- **Telefax:** +60 3 2201 3359
- **Website :** www.kongsberg.com/simrad
- **Email address:** simrad.asia@simrad.com

Korea

- **Company name:** Kongsberg Maritime Korea Ltd
- **Address:** #1101 Harbor Tower, 113-1, Nampodong 6-Ga, Jung-Gu, Busan 600-046, Korea
- **Telephone:** +82 51 242 9933
- **Telefax:** +82 51 242 9934
- **Website :** www.kongsberg.com/simrad
- **Email address:** simrad.korea@simrad.com

China

- **Company name:** Kongsberg Maritime China Ltd
- **Address:** 555 Chuanqiao Road, China (Shanghai) Pilot Free Trade Zone, 201206, China
- **Telephone:** +86 21 3127 9888
- **Telefax:** +86 21 3127 9555
- **Website :** www.kongsberg.com/simrad
- **Email address:** simrad.china@simrad.com

Technical specifications

Topics

[Introduction to technical specifications, page 34](#)

[Performance specifications, page 34](#)

[Power requirements, page 38](#)

[Weights and outline dimensions, page 41](#)

[Environmental requirements, page 45](#)

[Compass safe distance, page 48](#)

[Minimum display requirements, page 50](#)

Introduction to technical specifications

These technical specifications summarize the main functional and operational characteristics of the SX90 Fish-finding sonar. They also provide information related to power requirements, physical properties and environmental conditions.

Note

At Kongsberg Maritime, we are continuously working to improve the quality and performance of our products. The technical specifications may be changed without prior notice.

Related topics

[Technical specifications, page 33](#)

Performance specifications

These performance specifications summarize the main functional and operational characteristics of the SX90 system.

Operating frequency

Frequency range:

- Start frequency: 20 kHz
- End frequency: 30 kHz
- Frequency steps: 1 kHz

Operational range

- Minimum: 25 metres
- Maximum: 5.000 metres
- Extended range: 10.000 metres

Even though you can choose a large range value, that does not mean that you can detect your targets on the same range. The range value only defines the range that is shown in the views. Actual target detection will always depend on the operational environment, such as water temperature, salinity, interference and layers in the water column.

Tilt function

- **Horizontal views:** -10 to +60 degrees
- **Vertical views:** 0 to +90 degrees
- **Plane view:** -10 to +90 degrees
- **Inspection view:** -10 to +60 degrees

Note

The tilt limits depend on the opening angle of the vertical beam. This means that you may not always be permitted to select the maximum specified tilt limits.

Transmission

- **Number of transmitter channels:** 256
- **Horizontal TX Sector:**

	Maximum	Other options
Horizontal swath	360 degrees	30, 60, 90, 120, 180 degrees
Vertical swath	Normal	Narrow
Plane swath	180 degrees	30, 60, 90, 120 degrees
Inspection beams	-	-

- **Vertical TX Sector:**

	Maximum	Other options
Horizontal swath	Wide	Narrow, Normal, Auto
Vertical swath	90 degrees	30, 60 degrees
Plane swath	Wide	Narrow, Normal, Auto
Inspection beams	-	-

The options provided by these functions depend on your current active view.

Pulse types

- CW (Continuous Wave)
- LFM (Linear Frequency Modulation) (This pulse type is also known as "chirp".)
- Auto

Reception

- **Number of receiver channels:** 256
- **Gain functions:**
 - TVG (Time Variable Gain)
 - AGC (Automatic Gain Control)
 - RCG (Reverberation Controlled Gain)
- **Digital filters:**
 - Ping-Ping Filter
 - Noise Filter

- FM Correlation filter
- Target Threshold

Echo presentations

- **Display resolution:** 1280 x 1024 pixels (Minimum). The visual quality of the presentation depends on the quality of your graphic adapter and display. We recommend that you use a large display with resolution 1920 x 1080.
- **Colours:** A selection of echo colours is available to fit your presentation preferences. Each selection represents a dedicated colour scale.
- **Palettes:** A choice of colour palettes is available to fit ambient light conditions.

Stabilization

- **Roll stabilisation:** ± 20 degrees (Automatic)
- **Pitch stabilisation:** ± 20 degrees (Automatic)
- **External stabilisation sensor:** The SX90 system has been designed to match the motion reference unit (MRU) sensors manufactured by our Seatex division. Interface to an optional peripheral motion reference unit (MRU) is supported.

Interfaces

- **Interfaces to peripheral devices:**
 - Serial lines
 - Ethernet (LAN) line
- **Optional interfaces:**
 - Scientific output (NetCDF)

Note

NetCDF output requires a dedicated software license.

User interface

- **Main control:** The Operating Panel offers all necessary control functions for normal operation.
- **Secondary control:** A comprehensive menu system allows access to all SX90 system functionality.
- **Optional control:**
 - You can use a standard computer mouse to control the SX90 system.

- You can use a Microsoft Xbox Controller to make basic adjustments to the sonar operation.
- **Menu languages:** The text in the menu buttons in the user interface can be provided in several different languages. With a few exceptions, the chosen language is also used for all other texts.

Hull Unit

The SX90 system can be provided with one of the following hull units:

Hull Unit	Lowering depth (m)	Transducer cable (m)	Maximum speed (knots)
SX92	1.2	4.6	25
SX93	1.6	4.6	20
SX95	1.0	4.6	12
The same transducer is used on all hull unit types.			

Installation trunk

The installation trunk is not included in the standard delivery. The installation trunk may be fabricated by the shipyard, or supplied by us as an option.

Type approval: DnV Certificate S-6344

Transducer

The same transducer is used on all hull unit types.

Shape: Cylindrical

Number of individual elements: 256

Related topics

[Technical specifications, page 33](#)

Power requirements

These power characteristics summarize the supply power requirements for the SX90 system.

Topics

[Display power requirements, page 38](#)

[Operating Panel power requirements \(Mk1\), page 38](#)

[Operating Panel power requirements \(Mk2\), page 39](#)

[Operating Panel power requirements \(Mk3\), page 39](#)

[Transceiver Unit power requirements, page 39](#)

[Hull Unit power requirements, page 40](#)

Display power requirements

Not applicable. The display is not a part of the SX90 scope of supply. It is not manufactured by Kongsberg Maritime. For more information, refer to the end-user documentation provided by the manufacturer.

Related topics

[Technical specifications, page 33](#)

[Power requirements, page 38](#)

Operating Panel power requirements (Mk1)

Operating Panel

- **Make and model:** SX90 Operating Panel Mk1
- **Power requirements:** Not applicable. This unit is not powered by AC mains.

Operating Panel Power Supply

- **Make and model:** SX90 Operating Panel Power Supply
- **Power requirements:** 115/230 VAC, 47 to 63 Hz, single phase, nominal
- **Maximum voltage deviation:** 15%
- **Maximum transient:** 20% of nominal voltage, recovery time 3 s
- **Power consumption:** 10 VA (Approximately)

The power supply is connected to a dedicated socket on the rear side of the Processor Unit.

Related topics

[Technical specifications, page 33](#)

[Power requirements, page 38](#)

Operating Panel power requirements (Mk2)

- **Make and model:** SX90 Operating Panel (Mk2)
- **Voltage requirement:** 115/230 VAC, 47 to 63 Hz, single phase, nominal
- **Maximum voltage deviation:** 15%
- **Maximum transient:** 20% of nominal voltage, recovery time 3 s
- **Power consumption:** 10 W (Approximately)

Related topics

[Technical specifications, page 33](#)

[Power requirements, page 38](#)

Operating Panel power requirements (Mk3)

- **Make and model:** SX90 Operating Panel Mk3
- **Voltage requirement:** Not applicable

This unit is powered by means of the USB connection.

Related topics

[Technical specifications, page 33](#)

[Power requirements, page 38](#)

Transceiver Unit power requirements

- **Make and model:** SX90 Transceiver Unit
- **Voltage requirement:** 230 VAC, 47 to 63 Hz, single phase, nominal
- **Maximum voltage deviation:** 15 %
- **Maximum transient:** 20% of nominal voltage, recovery time 3 s
- **Power consumption:** 600 VA (Approximately)

Related topics

[Technical specifications, page 33](#)

[Power requirements, page 38](#)

Hull Unit power requirements

- **Make:** SX90 Hull Unit
- **Model:** All models
- **Voltage requirement:** 230/380/440 VAC
(47 to 63 Hz/3-phase/Nominal voltage)
- **Maximum voltage deviation:**
 - 230 VAC: 15%
 - 380/440 VAC: 340 to 485 VAC
- **Maximum transient:** 20% of nominal voltage, recovery time 3 s
- **Power consumption:** 3000 VA (Approximately)
- **Circuit breaker requirements:**

When the hoist motor starts, it draws a lot of power. It is therefore important that the electric supply is equipped with a suitable circuit breaker. The circuit breaker must be able to withstand the large starting current. We recommend using circuit breaker with one of the following ratings:

- 16D
- 20C

The circuit breaker is labeled with the rated current in amperes, but excluding the unit symbol, A. Instead, the ampere figure is preceded by a letter, *B*, *C*, or *D*, which indicates the *instantaneous tripping current*. That is the minimum value of current that causes the circuit breaker to trip without intentional time delay. In general terms, the *C* type circuit breaker will withstand 10 times the rated current for a short period of time. The *D* type circuit breaker will withstand 20 times the rated current. For more information, see standard *BS EN 60898*.

Related topics

[Technical specifications, page 33](#)

[Power requirements, page 38](#)

Weights and outline dimensions

These weights and outline dimension characteristics summarize the physical properties of the SX90 system.

Topics

[Display weight and outline dimensions, page 41](#)

[Enix Processor Unit weight and outline dimensions, page 41](#)

[Operating Panel weight and outline dimensions \(Mk1\), page 42](#)

[Operating Panel weight and outline dimensions \(Mk2\), page 42](#)

[Operating Panel weight and outline dimensions \(Mk3\), page 42](#)

[Transceiver Unit weight and outline dimensions, page 43](#)

[Hull Unit weight and outline dimensions, page 43](#)

Display weight and outline dimensions

Not applicable. The display is not a part of the SX90 scope of supply. It is not manufactured by Kongsberg Maritime. For more information, refer to the end-user documentation provided by the manufacturer.

Related topics

[Technical specifications, page 33](#)

[Weights and outline dimensions, page 41](#)

Enix Processor Unit weight and outline dimensions

- **Make and model:** SX90 Processor Unit (Enix)
- **Outline dimensions:**
 - **Depth:** 385 mm
 - **Width:** 479.6 mm (Will fit in a 19" rack)
 - **Height:** 177 mm
- **Weight:** 16 kg (Approximately)

The technical specifications are those valid for the computer that is provided by Kongsberg Maritime as a part of the SX90 system.

Related topics

[Technical specifications, page 33](#)

[Weights and outline dimensions, page 41](#)

Operating Panel weight and outline dimensions (Mk1)

- **Make and model:** SX90 Operating Panel Mk1
- **Outline dimensions:**
 - **Depth:** 165 mm
 - **Width:** 385 mm
 - **Height:** 51 mm
- **Weight:** 4 kg (Approximately)

Related topics

[Technical specifications, page 33](#)

[Weights and outline dimensions, page 41](#)

Operating Panel weight and outline dimensions (Mk2)

- **Make and model:** SX90 Operating Panel (Mk2)
- **Outline dimensions:**
 - **Depth:** 183 mm
 - **Width:** 346 mm
 - **Height:** 123 mm
- **Weight:** 3.7 kg (Approximately)

Related topics

[Technical specifications, page 33](#)

[Weights and outline dimensions, page 41](#)

Operating Panel weight and outline dimensions (Mk3)

- **Make and model:** SX90 Operating Panel Mk3
- **Outline dimensions:**
 - **Depth:** 57 mm
 - **Width:** 225 mm
 - **Height:** 125 mm
- **Weight:** 0.45 kg (Approximately)

Related topics

[Technical specifications, page 33](#)

[Weights and outline dimensions, page 41](#)

Transceiver Unit weight and outline dimensions

A new transceiver cabinet was introduced in late 2022. The new cabinet is identified as Mk2. The new cabinet is slightly wider than the Mk1 version. To identify which version you have, observe the order number in your order confirmation, or the part number on the cabinet's identification label.

Transceiver Unit Mk2

- **Make and model:** SX90 Transceiver Unit (Mk2)
- **Outline dimensions:**
 - **Depth:** 551 mm (With shock absorbers)
 - **Width:** 600 mm (Without the large transceiver plug)
 - **Height:** 777 mm (With shock absorbers)
- **Weight:** 65 kg (Approximately)

Transceiver Unit Mk1

This information is provided for legacy reasons.

- **Make and model:** SX90 Transceiver Unit (Mk1)
- **Outline dimensions:**
 - **Depth:** 665 mm (With shock absorbers)
 - **Width:** 520 mm (Without the large transceiver plug)
 - **Height:** 750 mm (With shock absorbers)
- **Weight:** 75 kg (Approximately)

Related topics

[Technical specifications, page 33](#)

[Weights and outline dimensions, page 41](#)

Hull Unit weight and outline dimensions

- **Make:** SX90 Hull Unit
- **Model:** SX92
 - **Flange diameter:** 760 mm
 - **Number of holes in the flange:** 24
 - **Total height:** 2990 mm
 - **Height above the installation trunk:** 2120 mm
 - **Weight:** 1100 kg (Approximately)
- **Model:** SX93
 - **Flange diameter:** 760 mm

- **Number of holes in the flange:** 24
- **Total height:** 3388 mm
- **Height above the installation trunk:** 2518 mm
- **Weight:** 1200 kg (Approximately)
- **Model:** SX95
 - **Flange diameter:** 540 mm
 - **Number of holes in the flange:** 16
 - **Total height:** 2519 mm
 - **Height above the installation trunk:** 1645 mm
 - **Weight:** 520 kg (Approximately)

Related topics

[Technical specifications, page 33](#)

[Weights and outline dimensions, page 41](#)

Environmental requirements

These environmental specifications summarize the temperature and humidity requirements for the SX90 system.

Topics

[Display environmental requirements, page 45](#)

[Enix Processor Unit environmental requirements, page 45](#)

[Operating Panel environmental requirements \(Mk1\), page 46](#)

[Operating Panel environmental requirements \(Mk2\), page 46](#)

[Operating Panel environmental requirements \(Mk3\), page 46](#)

[Transceiver Unit environmental requirements, page 47](#)

[Hull Unit environmental requirements, page 47](#)

Display environmental requirements

Not applicable. The display is not a part of the SX90 scope of supply. It is not manufactured by Kongsberg Maritime. For more information, refer to the end-user documentation provided by the manufacturer.

Related topics

[Technical specifications, page 33](#)

[Environmental requirements, page 45](#)

Enix Processor Unit environmental requirements

- **Model:** SX90 Processor Unit (Enix)
- **Operating temperature:** -15 to 55 °C
- **Storage temperature:** -20 to 70 °C
- **Relative humidity:** 10 to 95% relative non-condensing
- **Certificates:**
 - IEC 60945
 - IACS E10

The technical specifications are those valid for the computer that is provided by Kongsberg Maritime as a part of the SX90 system.

Related topics

[Technical specifications, page 33](#)

[Environmental requirements, page 45](#)

Operating Panel environmental requirements (Mk1)

Operating Panel

- **Make and model:** SX90 Operating Panel Mk1
- **Operating temperature:** 0 to +50 °C
- **Storage temperature:** -40 to 70 °C
- **Relative humidity:** 5 to 95% relative, non-condensing

Operating Panel Power Supply

- **Make and model:** SX90 Operating Panel Power Supply
- **Operating temperature:** 0 to +50 °C
- **Storage temperature:** -40 to 70 °C
- **Relative humidity:** 5 to 95% relative, non-condensing

Related topics

[Technical specifications, page 33](#)

[Environmental requirements, page 45](#)

Operating Panel environmental requirements (Mk2)

- **Make and model:** SX90 Operating Panel (Mk2)
- **Operating temperature:** 0 to +50 °C
- **Storage temperature:** -40 to 70 °C
- **Relative humidity:** 5 to 95% relative, non-condensing

Related topics

[Technical specifications, page 33](#)

[Environmental requirements, page 45](#)

Operating Panel environmental requirements (Mk3)

- **Make and model:** SX90 Operating Panel Mk3
- **Operating temperature:** 0 to +50 °C
- **Storage temperature:** -40 to 70 °C

- **Relative humidity:** 5 to 95% relative, non-condensing
- **Ingress protection (IP) code:** IP65

Related topics

[Technical specifications, page 33](#)

[Environmental requirements, page 45](#)

Transceiver Unit environmental requirements

- **Make and model:** SX90 Transceiver Unit
- **Operating temperature:** 0 to +50 °C
- **Storage temperature:** -40 to 70 °C
- **Relative humidity:** 5 to 95% relative, non-condensing

Related topics

[Technical specifications, page 33](#)

[Environmental requirements, page 45](#)

Hull Unit environmental requirements

- **Make:** SX90 Hull Unit
- **Model:** All models
 - **Operating temperature:** 0 to +50 °C
 - **Storage temperature:** -20 to 40 °C
 - **Relative humidity:** 5 to 95% relative, non-condensing

Note _____

***Do not** expose the transducer to direct sunlight or excessive heat.*

Related topics

[Technical specifications, page 33](#)

[Environmental requirements, page 45](#)

Compass safe distance

If you place any of the SX90 Fish-finding sonar units on the bridge, you must observe the physical distance to the compass.

Topics

[Display compass safe distance, page 48](#)

[Processor Unit compass safe distance, page 48](#)

[Operating Panel compass safe distance \(Mk1\), page 48](#)

[Operating Panel compass safe distance \(Mk2\), page 49](#)

[Operating Panel compass safe distance \(Mk3\), page 49](#)

[Transceiver Unit compass safe distance, page 49](#)

[Hull Unit compass safe distance, page 49](#)

Display compass safe distance

Not applicable. The display is not a part of the SX90 scope of supply. It is not manufactured by Kongsberg Maritime. For more information, refer to the end-user documentation provided by the manufacturer.

Related topics

[Technical specifications, page 33](#)

[Compass safe distance, page 48](#)

Processor Unit compass safe distance

- **Model:** SX90 Processor Unit (Enix)
- **Standard compass:** 200 cm
- **Other compass:** 140 cm

Related topics

[Technical specifications, page 33](#)

[Compass safe distance, page 48](#)

Operating Panel compass safe distance (Mk1)

- **Make and model:** SX90 Operating Panel Mk1

- **Standard compass:** 30 cm
- **Other compass:** 20 cm

Related topics

[Technical specifications, page 33](#)

[Compass safe distance, page 48](#)

Operating Panel compass safe distance (Mk2)

- **Make and model:** SX90 Operating Panel Mk2
- **Standard compass:** 25 cm
- **Other compass:** 16.5 cm

Related topics

[Technical specifications, page 33](#)

[Compass safe distance, page 48](#)

Operating Panel compass safe distance (Mk3)

- **Make and model:** SX90 Operating Panel (Mk3)
- **Standard compass:** This information is currently not available.
- **Other compass:** This information is currently not available.

Related topics

[Technical specifications, page 33](#)

[Compass safe distance, page 48](#)

Transceiver Unit compass safe distance

- **Make and model:** SX90 Transceiver Unit
- **Compass safe distance:** Not applicable. The unit is not located on the bridge.

Related topics

[Technical specifications, page 33](#)

[Compass safe distance, page 48](#)

Hull Unit compass safe distance

- **Make:** SX90 Hull Unit
- **Compass safe distance:** Not applicable. The unit is not located on the bridge.

Related topics

[Technical specifications, page 33](#)

[Compass safe distance, page 48](#)

Minimum display requirements

Unless specifically ordered, the SX90 system is not provided with a display. The display must then be purchased locally.

You can use more than one display on your Processor Unit depending on personal and/or operational preferences.

Note

Make sure that the chosen display meets the requirements for the SX90 system. The design and construction must allow for marine use, and the display must be able to withstand the movements and vibrations normally experienced on a vessel. Verify that you have easy access to cables and connectors, and that the display can be installed in a safe and secure way.

The minimum technical requirements for the display are:

Resolution

Minimum requirement: 1280 x 1024 pixels

The visual quality of the presentation depends on the quality of your graphic adapter and display. We recommend that you use a large display with resolution 1920 x 1080 or 1920 x 1200.

Video interface

The video interface must match the output format(s) provided by the Processor Unit. The Processor Unit may offer video output on several formats. Investigate your options before you purchase a display.

Physical screen size

The screen size depends on personal and/or operational preferences. We recommend that you use 24 inch or bigger diagonal screen size. The SX90 software supports 16:9 and 16:10 displays.

Related topics

[Technical specifications, page 33](#)

Drawing file

Topics

- [About the drawings in the drawing file, page 52](#)
- [385609 Processor Unit outline dimensions Enix, page 53](#)
- [494024 Processor Unit outline dimensions \(HT20470/DC\), page 57](#)
- [494025 Processor Unit outline dimensions \(HT20470/AC\), page 60](#)
- [204688 Operating Panel dimensions \(Mk1\), page 63](#)
- [443179 Operating Panel dimensions \(Mk2\), page 65](#)
- [440689 Operating Panel cut-out drawing \(Mk2\), page 68](#)
- [439594 Operating Panel adapter plate \(Mk2\), page 69](#)
- [476352 Operating Panel dimensions \(Mk3\), page 71](#)
- [110-0003426 Transceiver dimensions \(Mk2\), page 74](#)
- [328873 Transceiver dimensions \(Mk1/Old\), page 77](#)
- [280328 Hull Unit dimensions SX92, page 80](#)
- [280328 Hull Unit dimensions SX93, page 83](#)
- [318900 Hull Unit dimensions SX95, page 86](#)
- [207481 Installation trunk dimensions SX92/SX93, page 89](#)
- [322202 Installation trunk dimensions SX95, page 91](#)
- [113361 Installation trunk SX95, page 92](#)
- [207485 Blind flange dimensions \(\$\varnothing\$ 760 mm\), page 94](#)
- [113362 Blind flange dimensions \(\$\varnothing\$ 580 mm\), page 95](#)
- [082973 Mounting flange DN500, page 96](#)
- [083045 Gate valve installation DN500, page 99](#)
- [33498 Gate valve dimensions DN500, page 101](#)
- [37357 Gate valve dimensions DN500, page 104](#)

About the drawings in the drawing file

Relevant drawings related to the installation and/or maintenance of the SX90 system are provided for information purposes only.

Note

These drawings are provided only for information and planning purposes. Information may be omitted. Observe the source drawings for additional details.

The drawings are not to scale. Unless otherwise specified, all measurements are in millimetres. The original installation drawings are available in PDF and/or AutoCad's DWG format. The original drawing can be downloaded from our website.

- www.kongsberg.com/simrad

Some drawings and documents are not available from our website. These can be downloaded from the *Simrad Dealer Club*.

- www.kongsberg.com/sdc

The installation shipyard must provide all necessary design and installation drawings, as well as the relevant work standards and mounting procedures.

If required, all documents provided by the shipyard for the physical installation of the SX90 system must be approved by the vessel's national registry and corresponding maritime authority and/or classification society. Such approval must be obtained before the installation can begin. The shipowner and shipyard doing the installation are responsible for obtaining and paying for such approval.

385609 Processor Unit outline dimensions Enix

Download the source drawing from our website: <https://www.kongsberg.com/sx90>

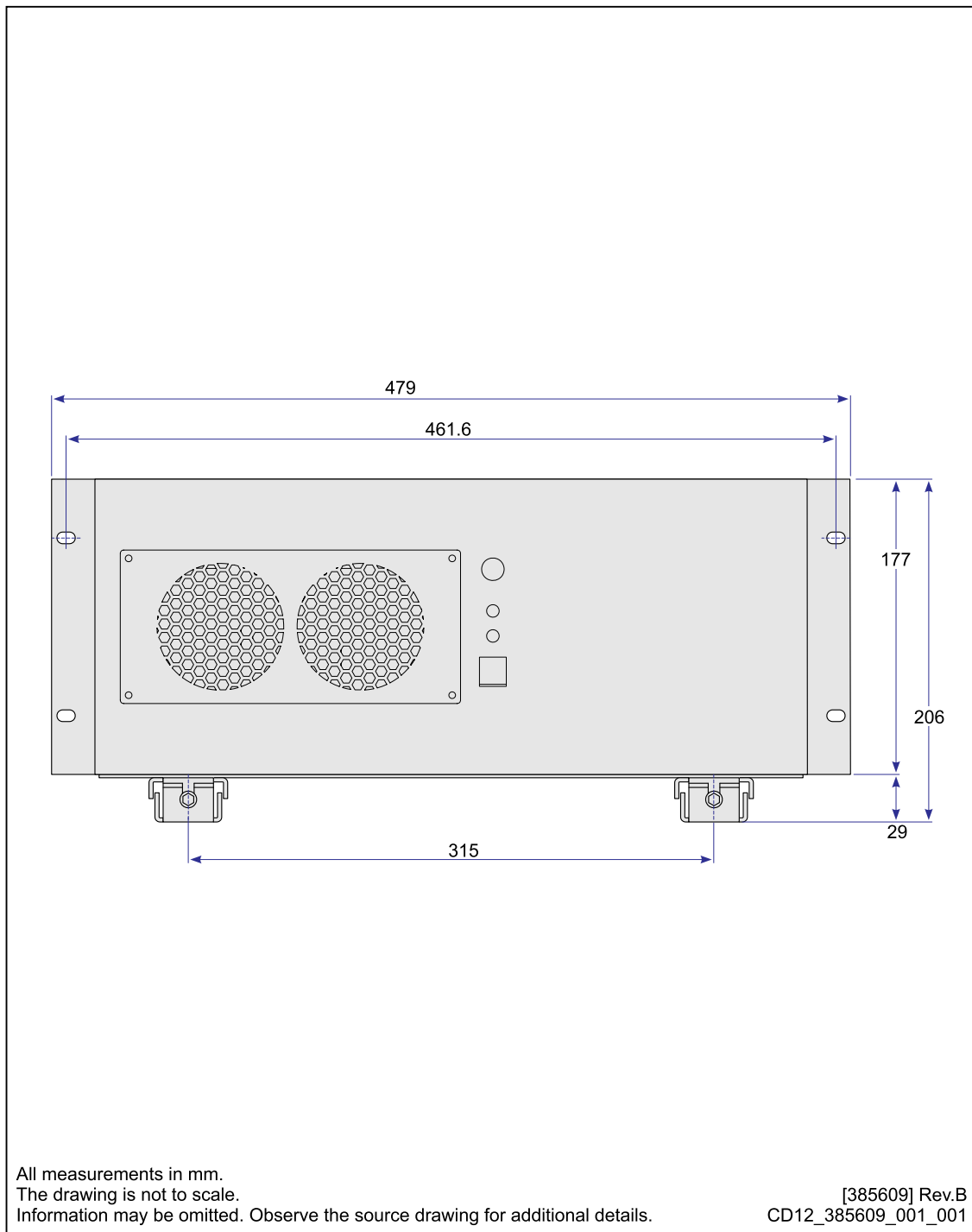

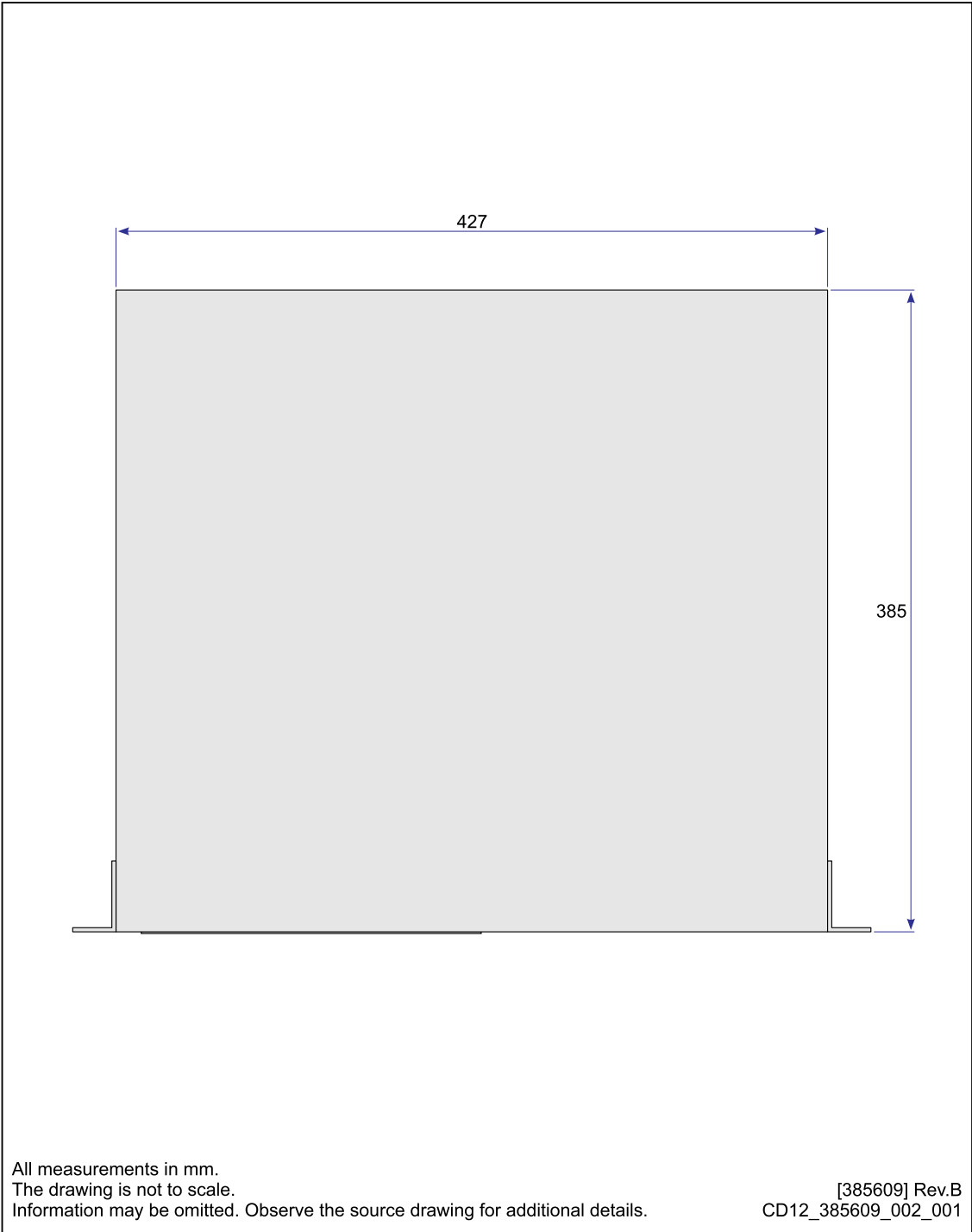

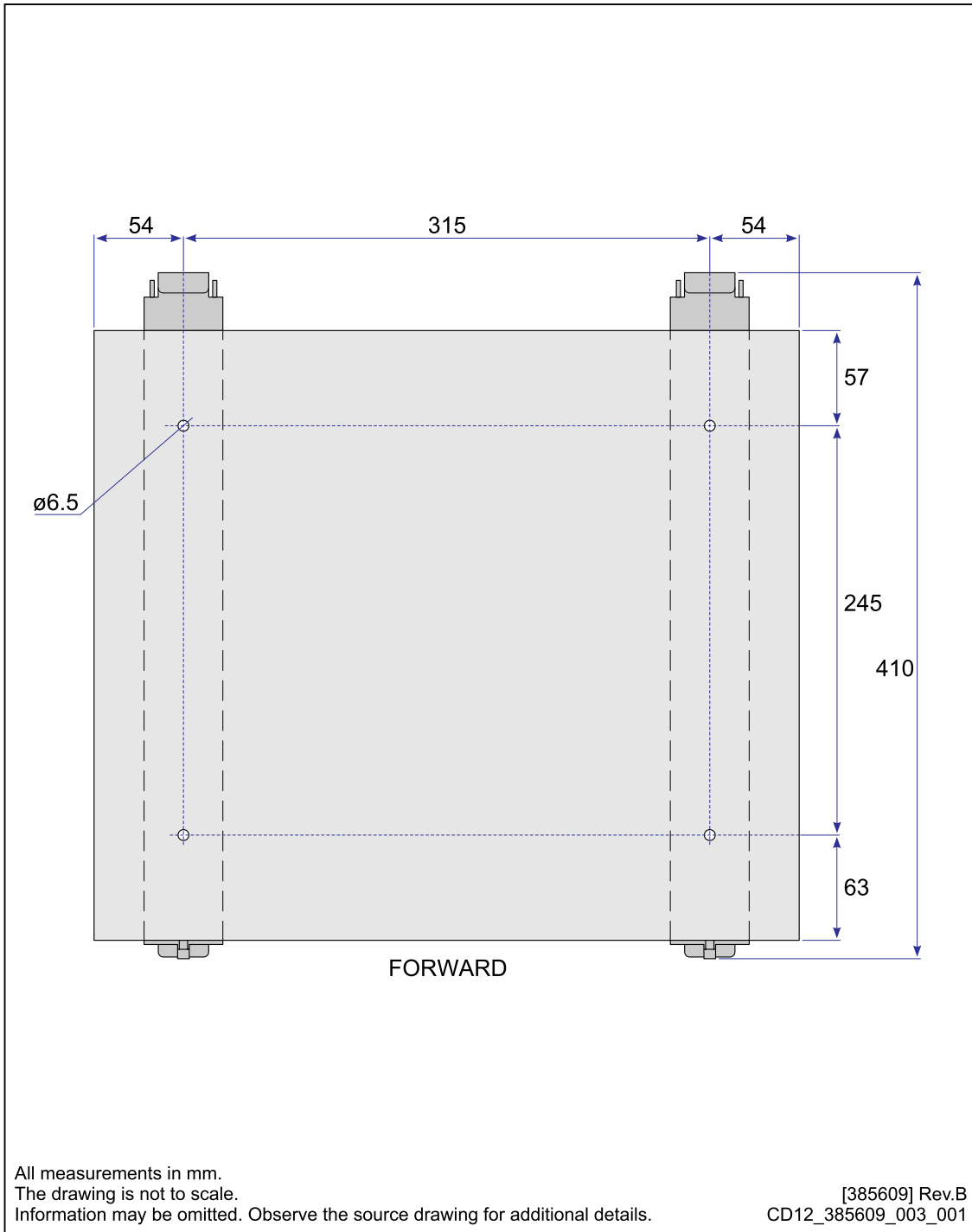

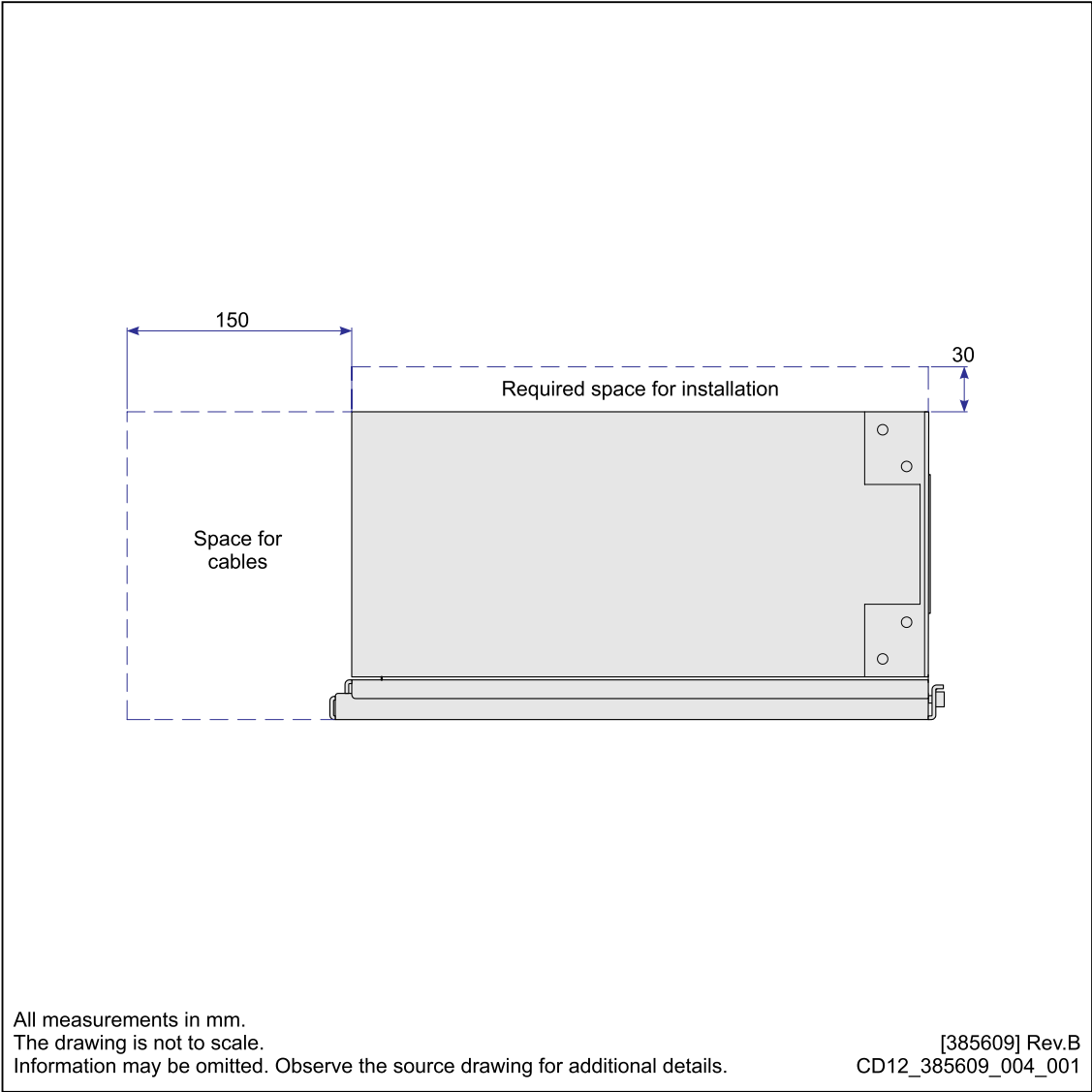

Related topics
[Drawing file, page 51](#)

494024 Processor Unit outline dimensions (HT20470/DC)

Download the source drawing from our website: <https://www.kongsberg.com/sx90>

Top and rear views

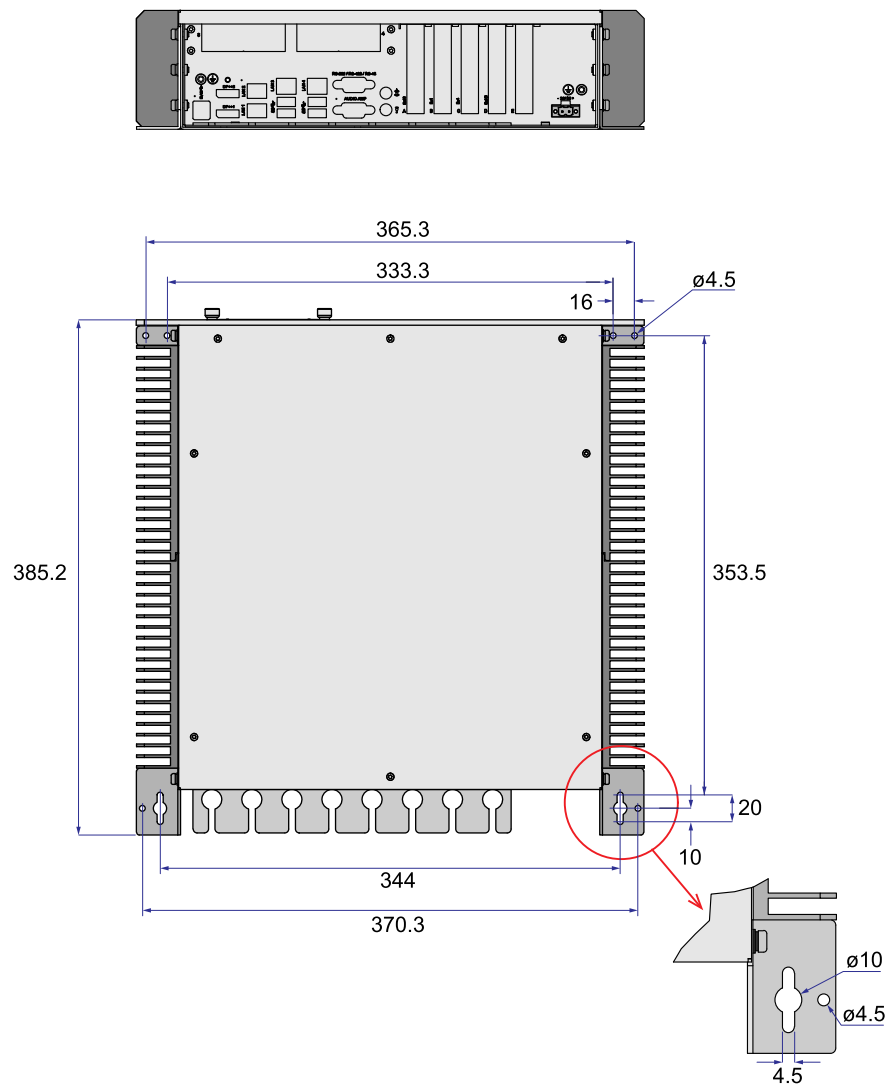

Weight: Approximately 7.5 kg

All measurements in mm.
The drawing is not to scale.
Information may be omitted. Observe the source drawing for additional details.

[494024] Rev.A
AI12_494024_001_001

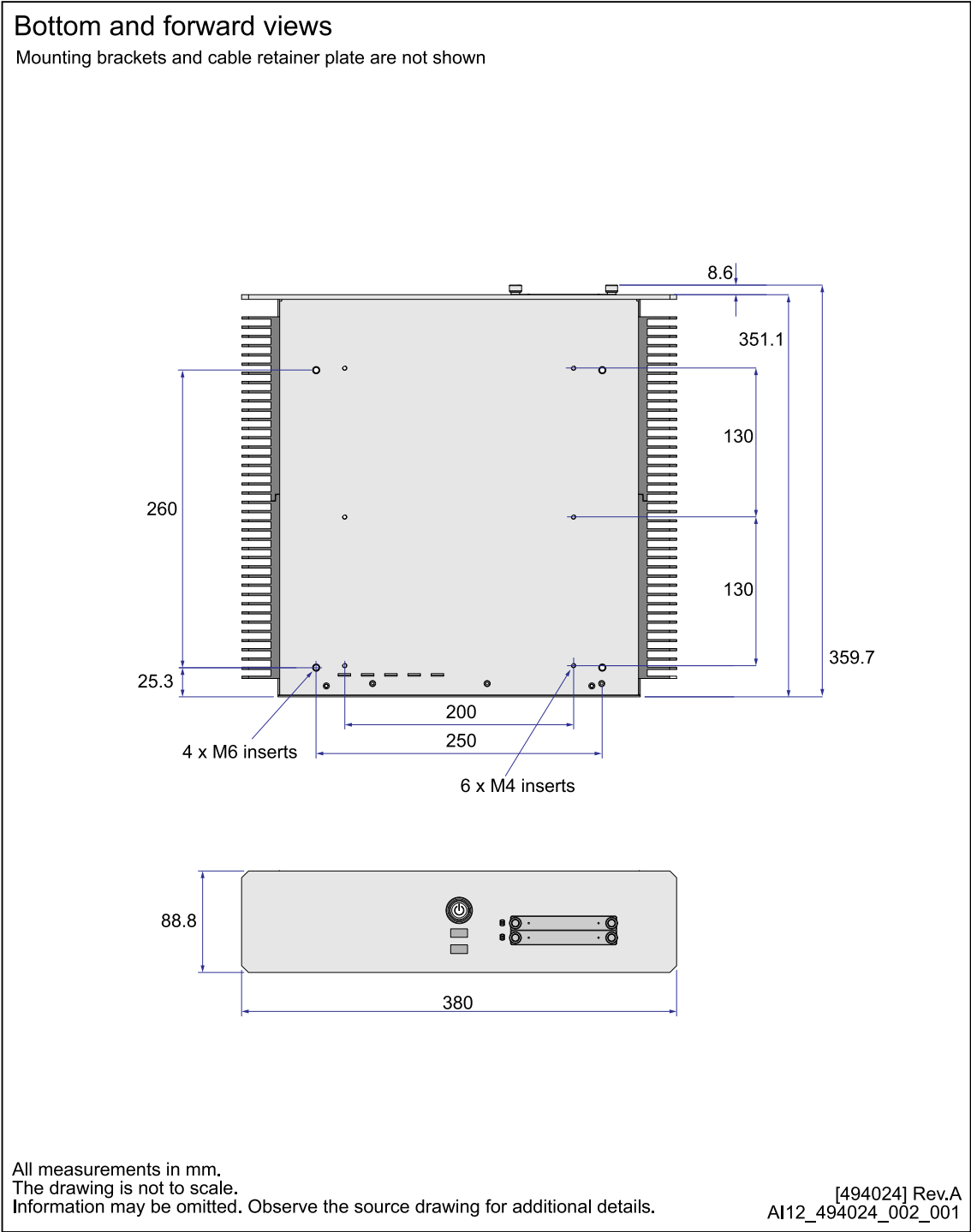

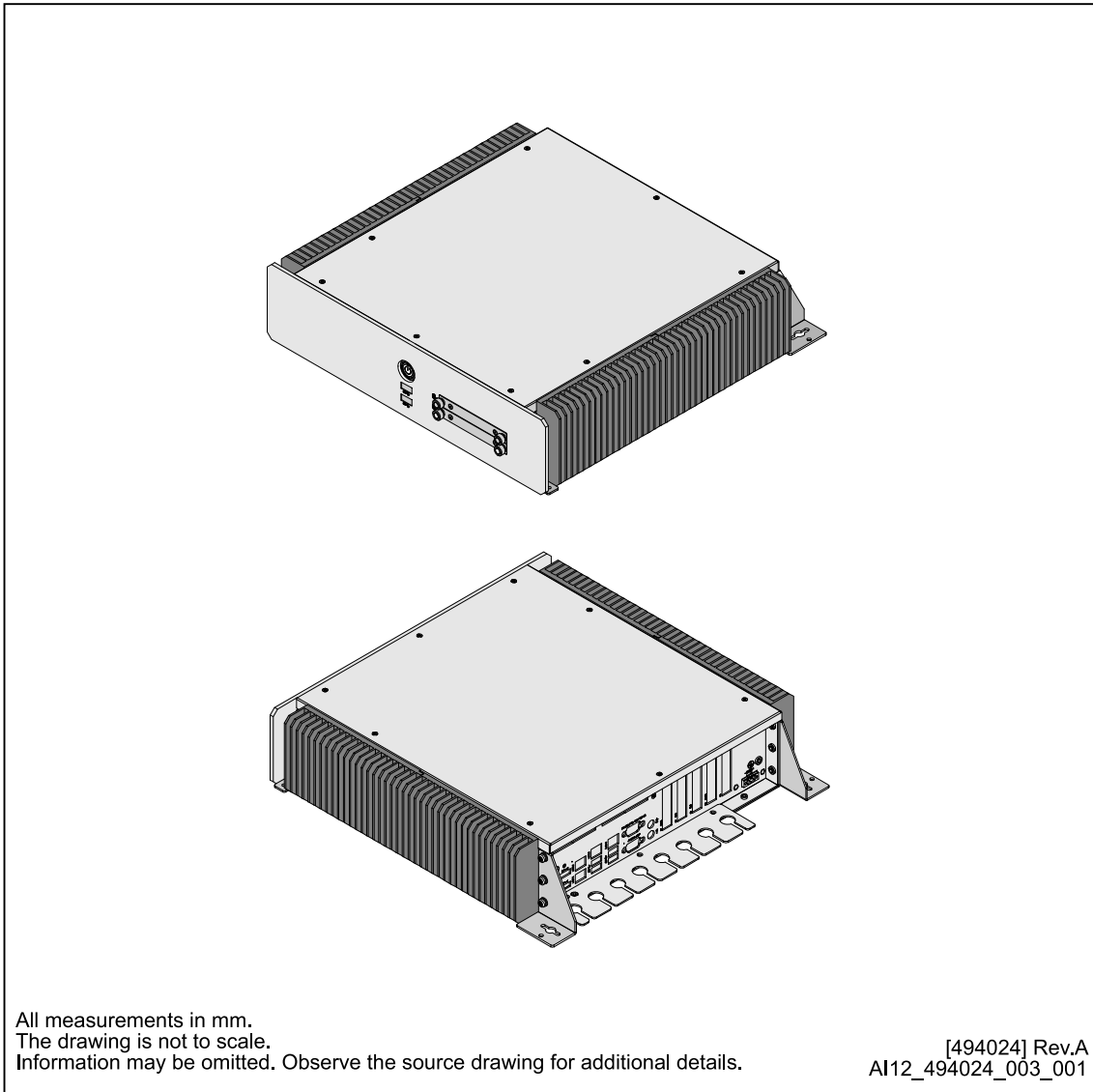

Related topics

[Drawing file, page 51](#)

494025 Processor Unit outline dimensions (HT20470/AC)

Download the source drawing from our website: <https://www.kongsberg.com/sx90>

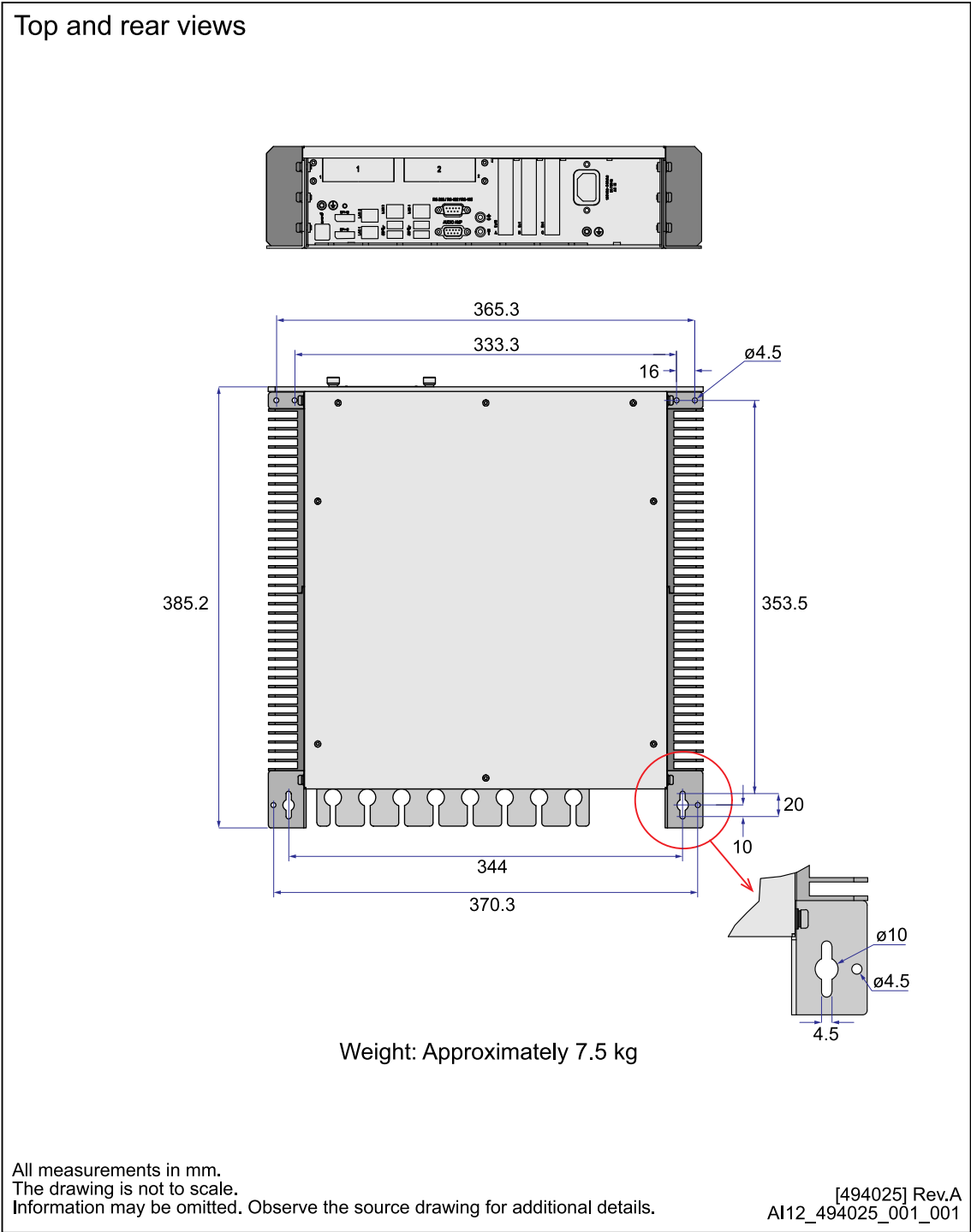

Bottom and forward views

Mounting brackets and cable retainer plate are not shown

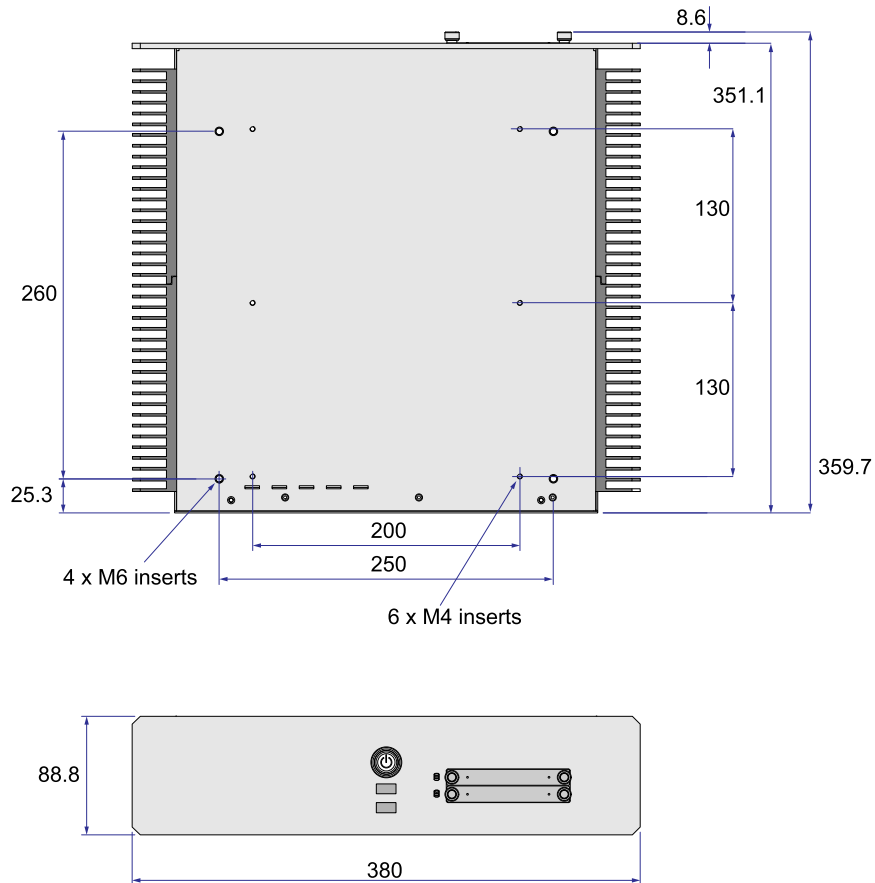

All measurements in mm.
 The drawing is not to scale.
 Information may be omitted. Observe the source drawing for additional details.

[494025] Rev.A
 AI12_494025_002_001

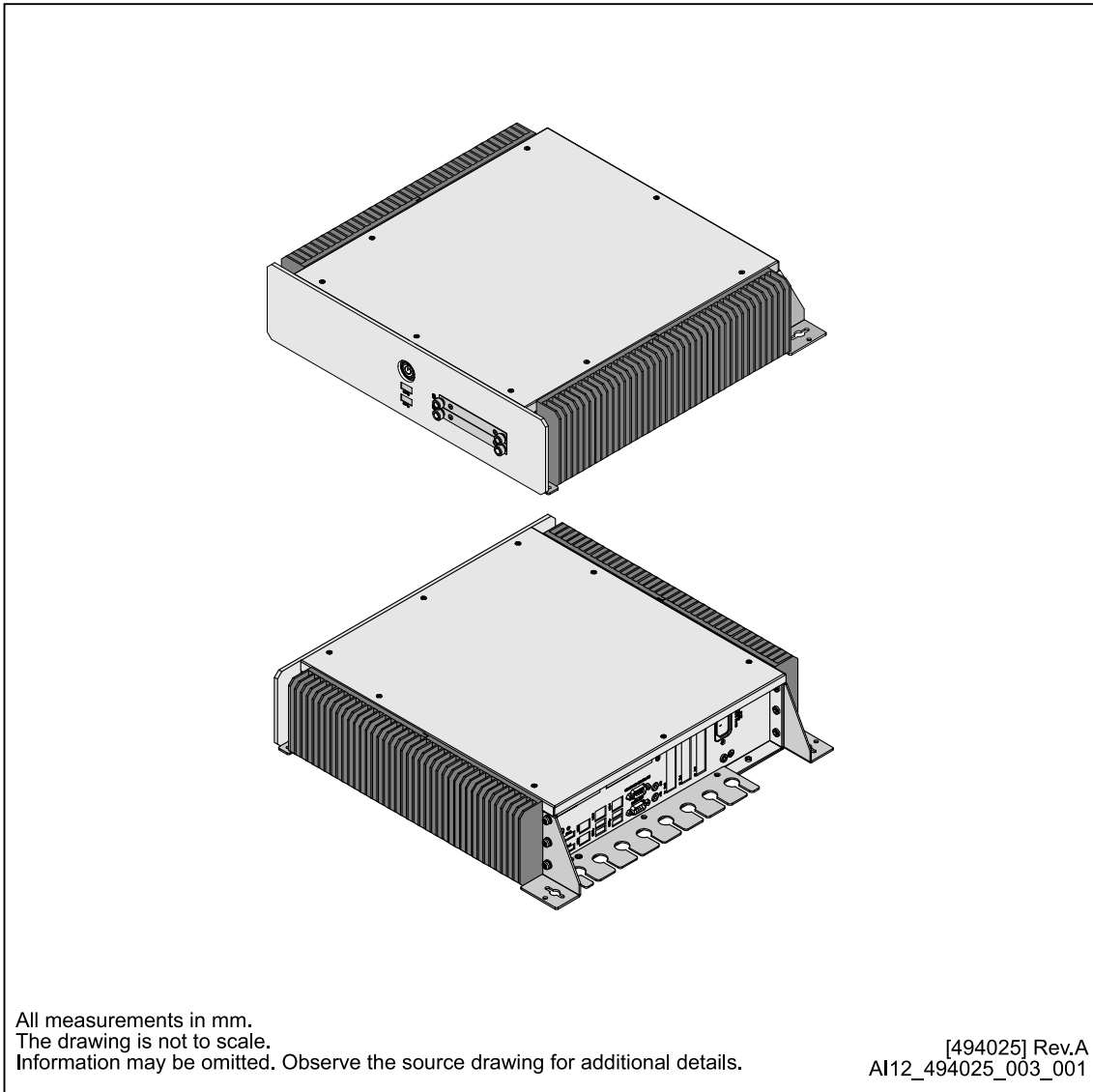

Related topics

[Drawing file, page 51](#)

204688 Operating Panel dimensions (Mk1)

Download the source drawing from our website: <https://www.kongsberg.com/sx90>

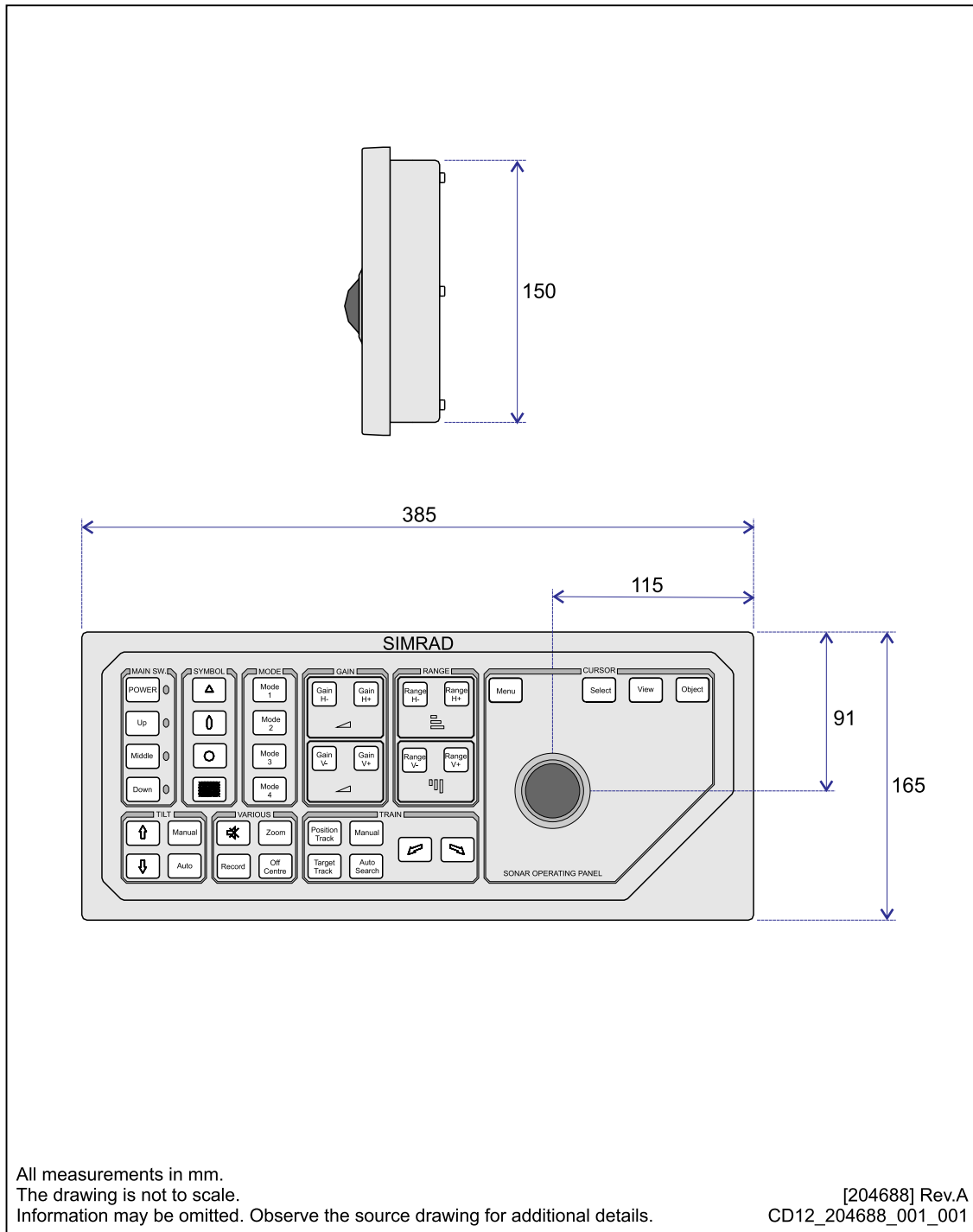

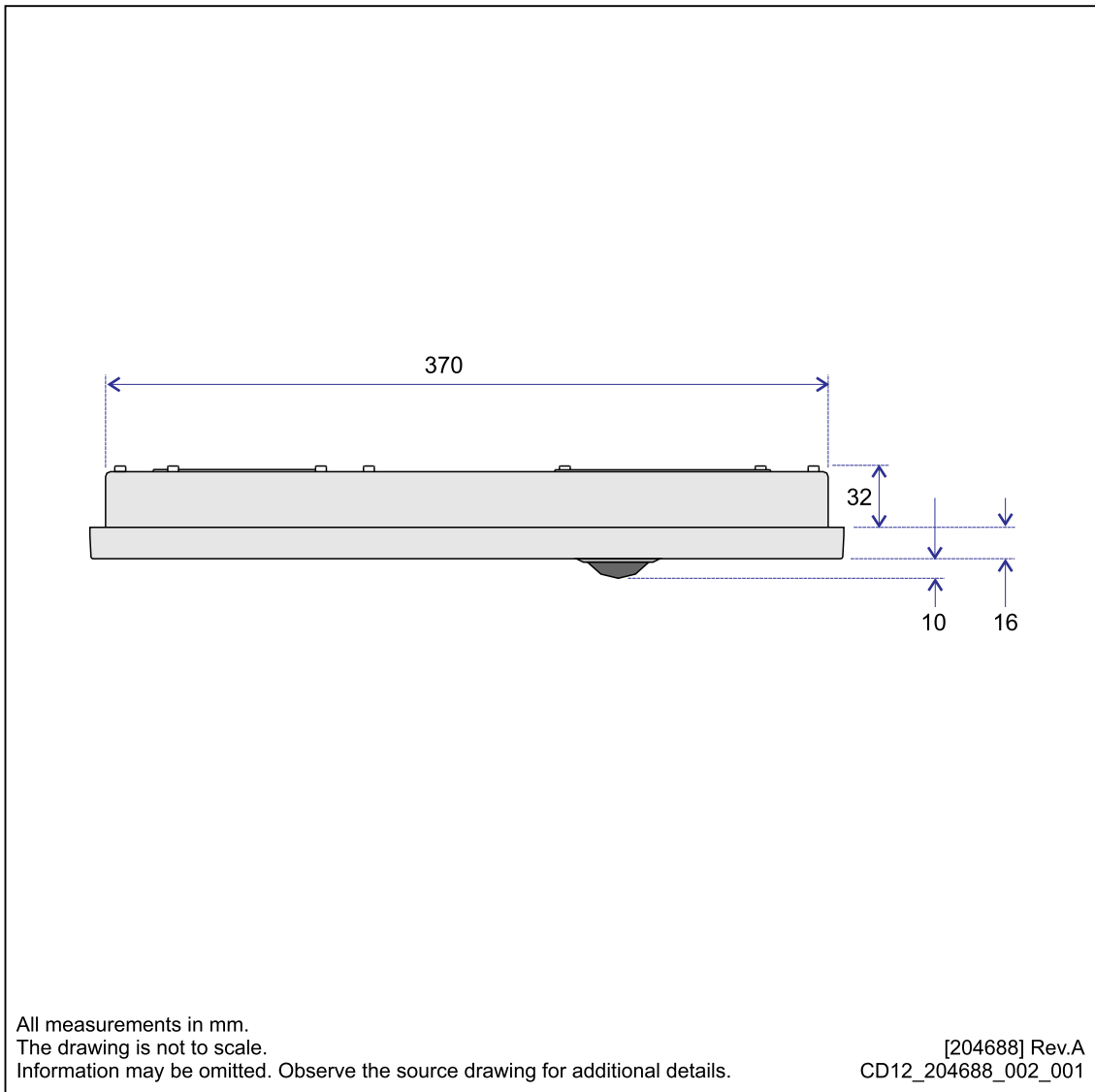

Related topics

[Drawing file, page 51](#)

443179 Operating Panel dimensions (Mk2)

Download the source drawing from our website: <https://www.kongsberg.com/sx90>

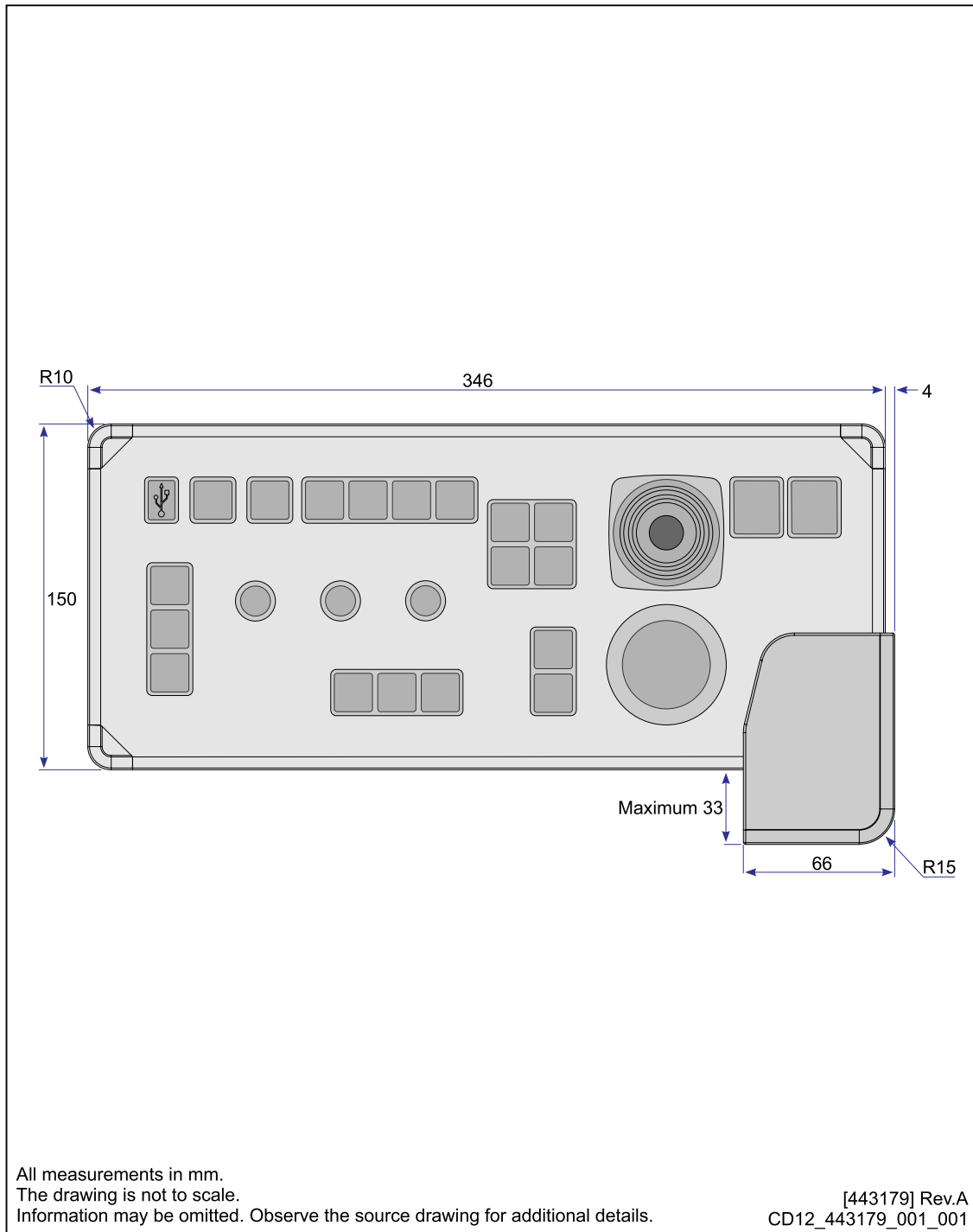

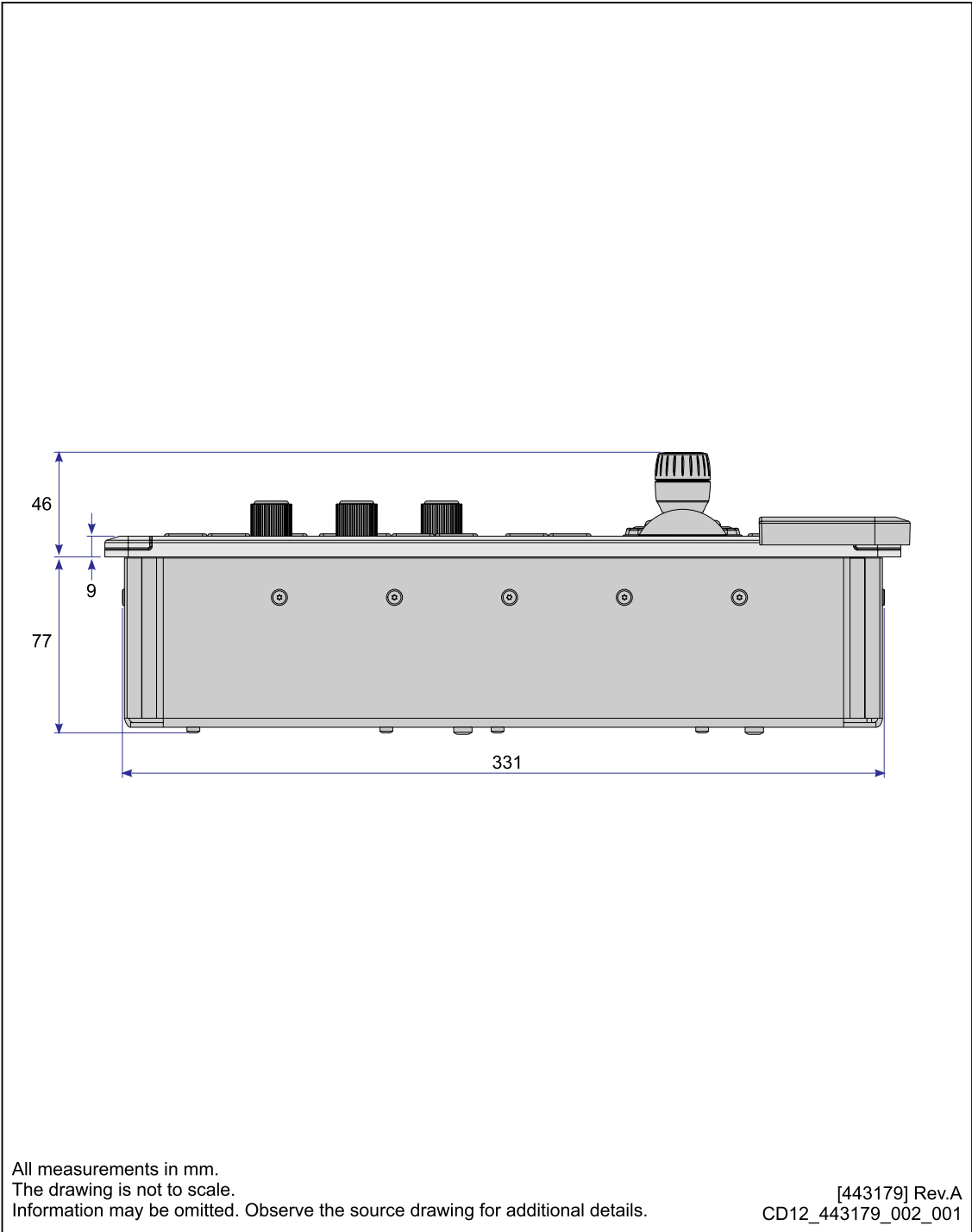

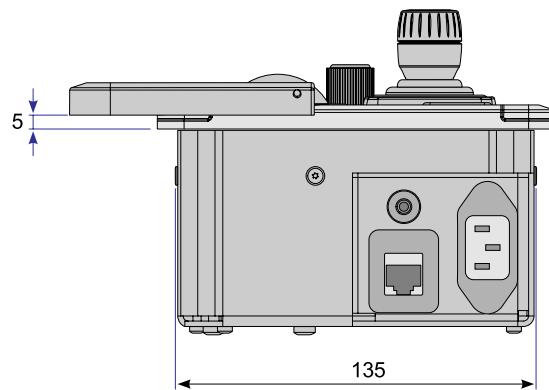

All measurements in mm.
The drawing is not to scale.
Information may be omitted. Observe the source drawing for additional details.

[443179] Rev.A
CD12_443179_003_001

Related topics

[Drawing file, page 51](#)

440689 Operating Panel cut-out drawing (Mk2)

Download the source drawing from our website: <https://www.kongsberg.com/sx90>

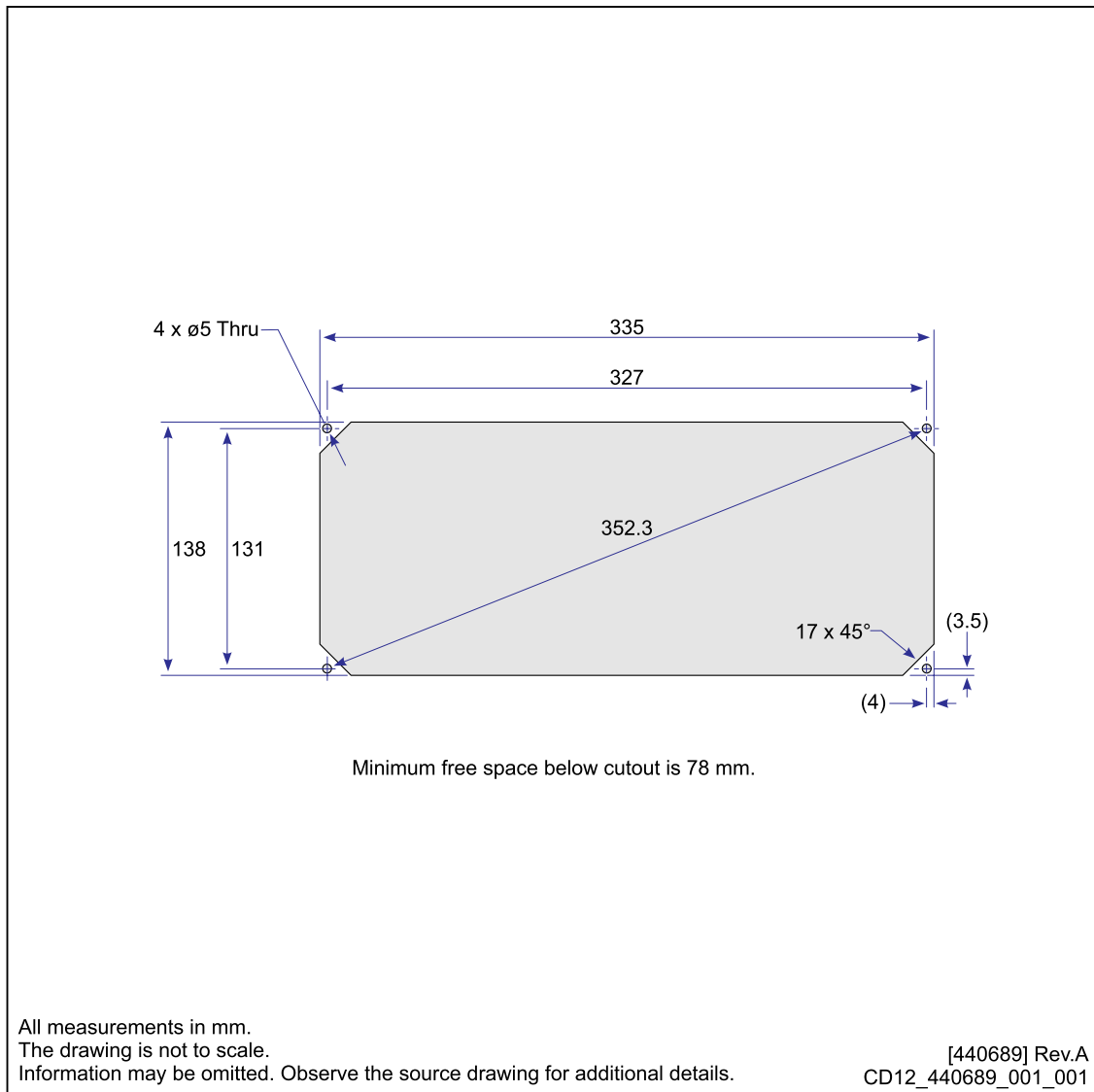

Related topics

[Drawing file, page 51](#)

439594 Operating Panel adapter plate (Mk2)

Download the source drawing from our website: <https://www.kongsberg.com/sx90>

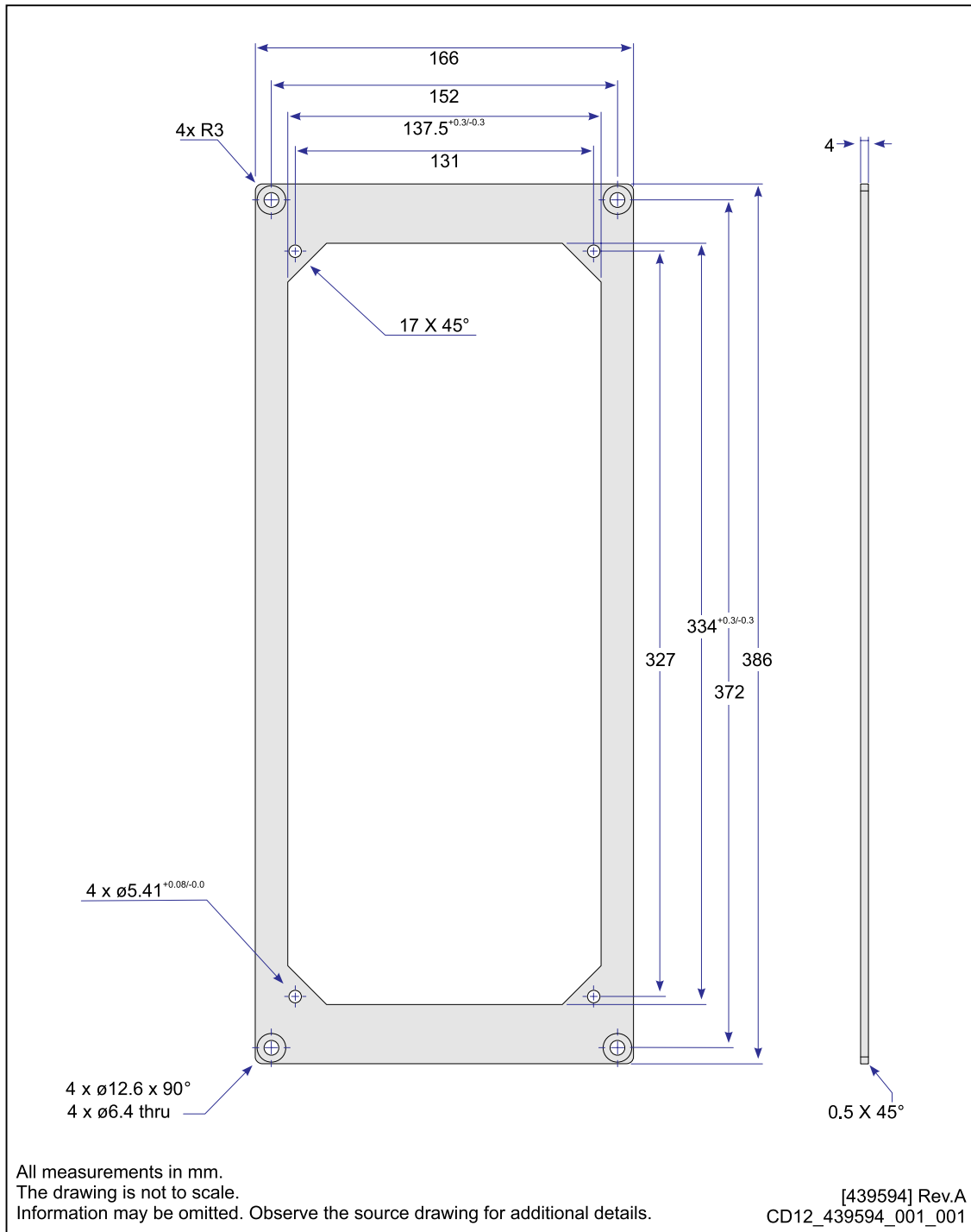

No sharp edges! Deburr.

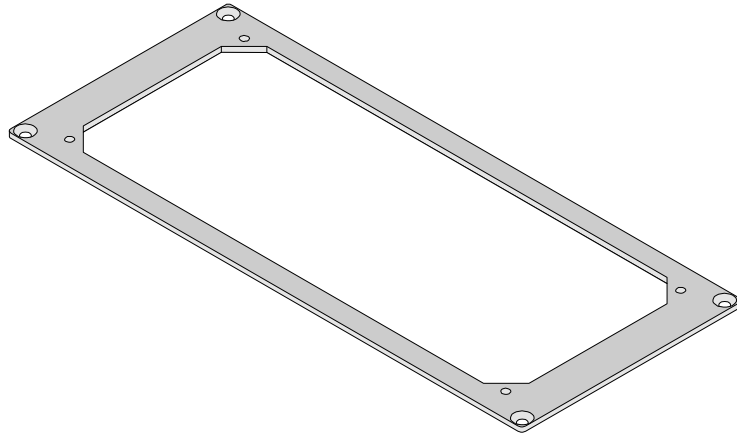

All measurements in mm.
The drawing is not to scale.
Information may be omitted. Observe the source drawing for additional details.

[439594] Rev.A
CD12_439594_002_001

Related topics

[Drawing file, page 51](#)

476352 Operating Panel dimensions (Mk3)

Download the source drawing from our website: <https://www.kongsberg.com/sx90>

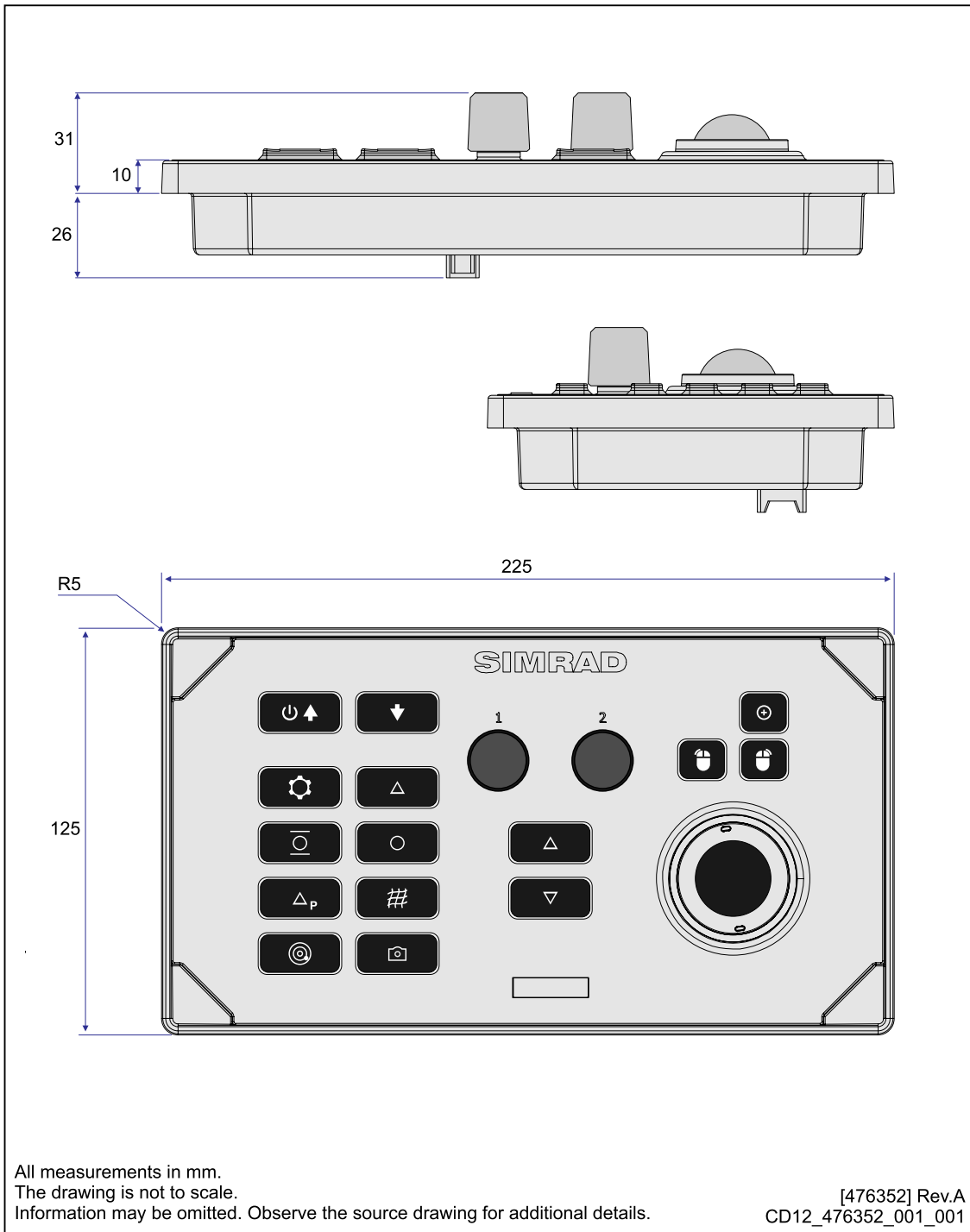

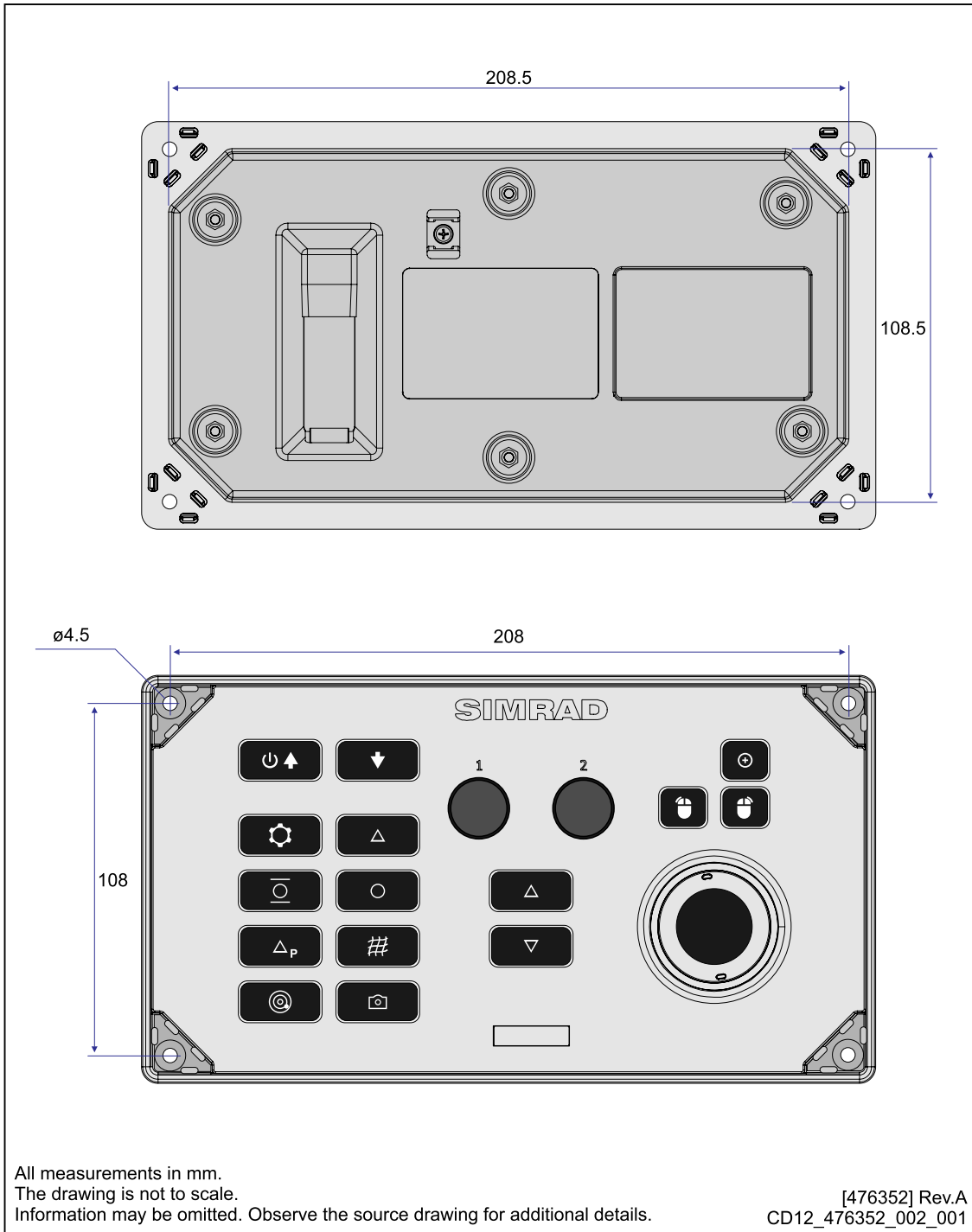

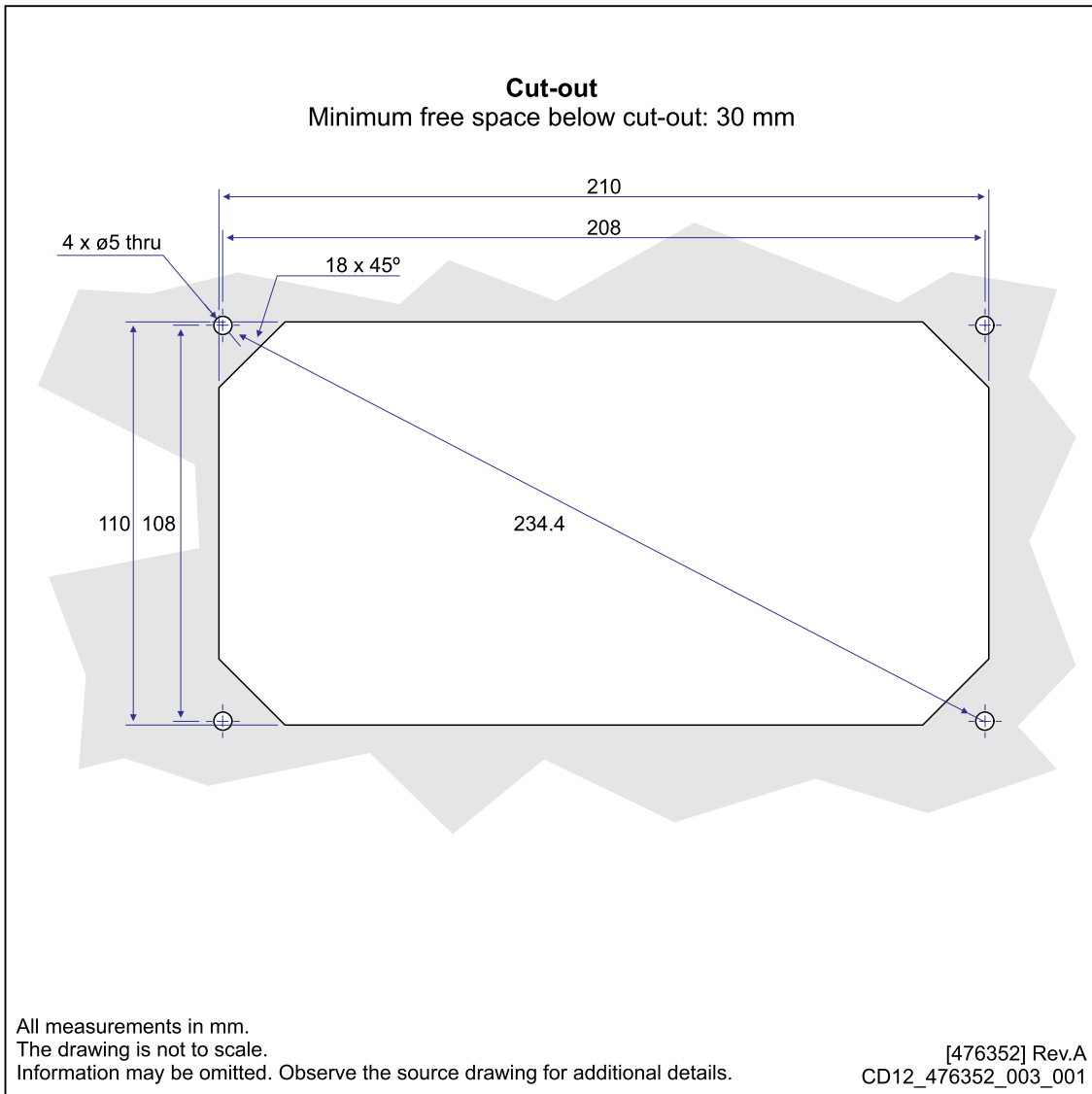

Related topics

[Drawing file, page 51](#)

110-0003426 Transceiver dimensions (Mk2)

Download the source drawing from our website: <https://www.kongsberg.com/sx90>

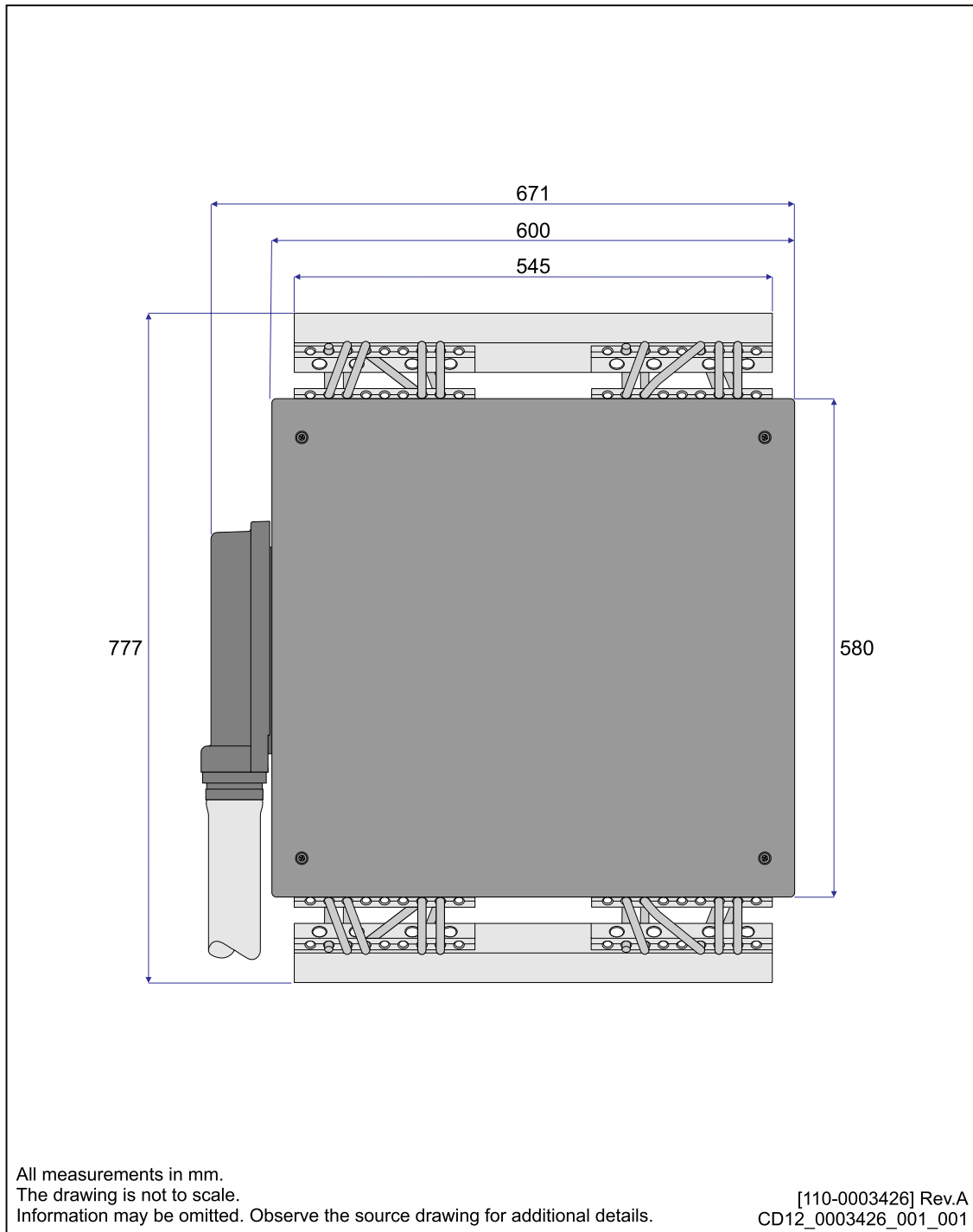

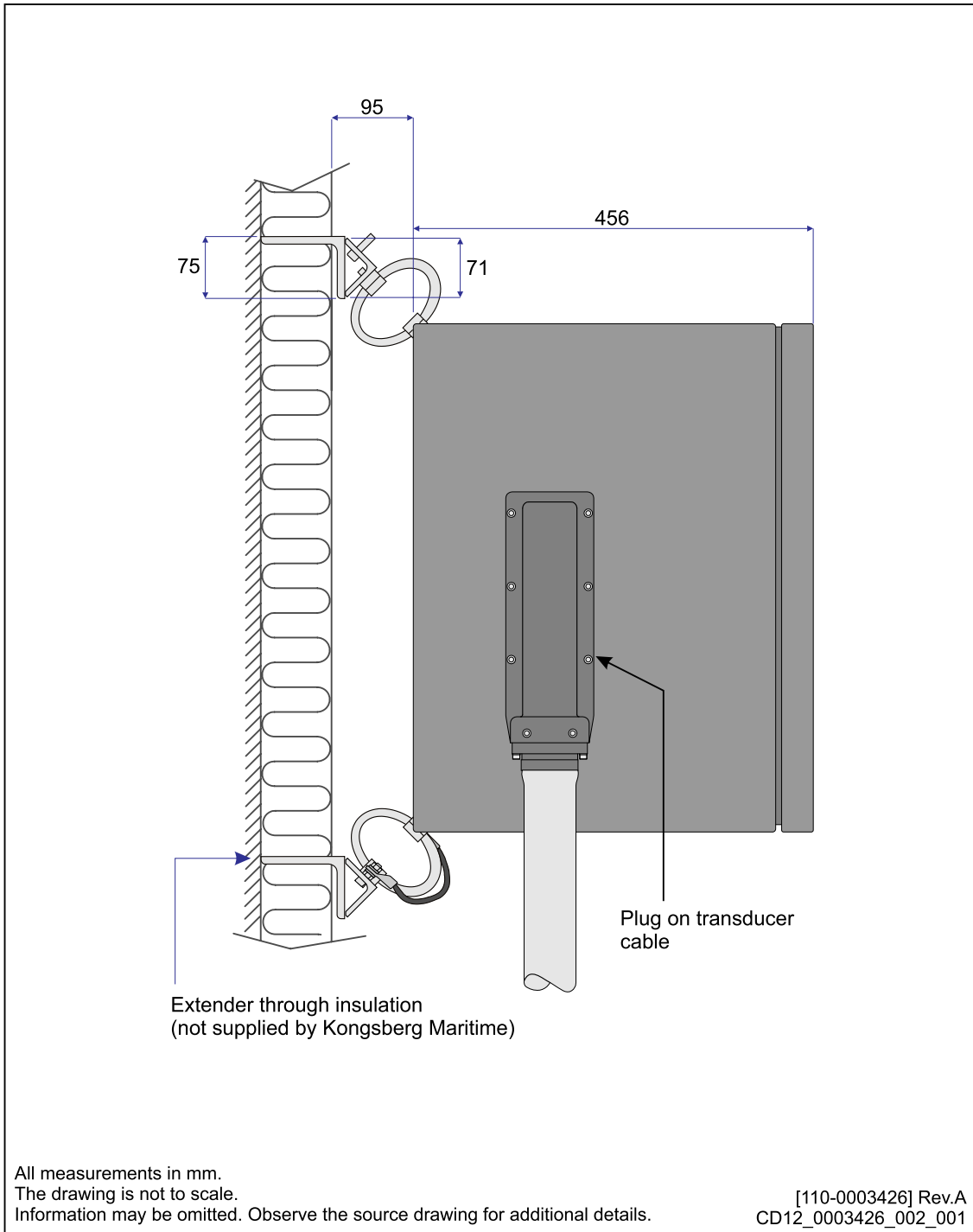

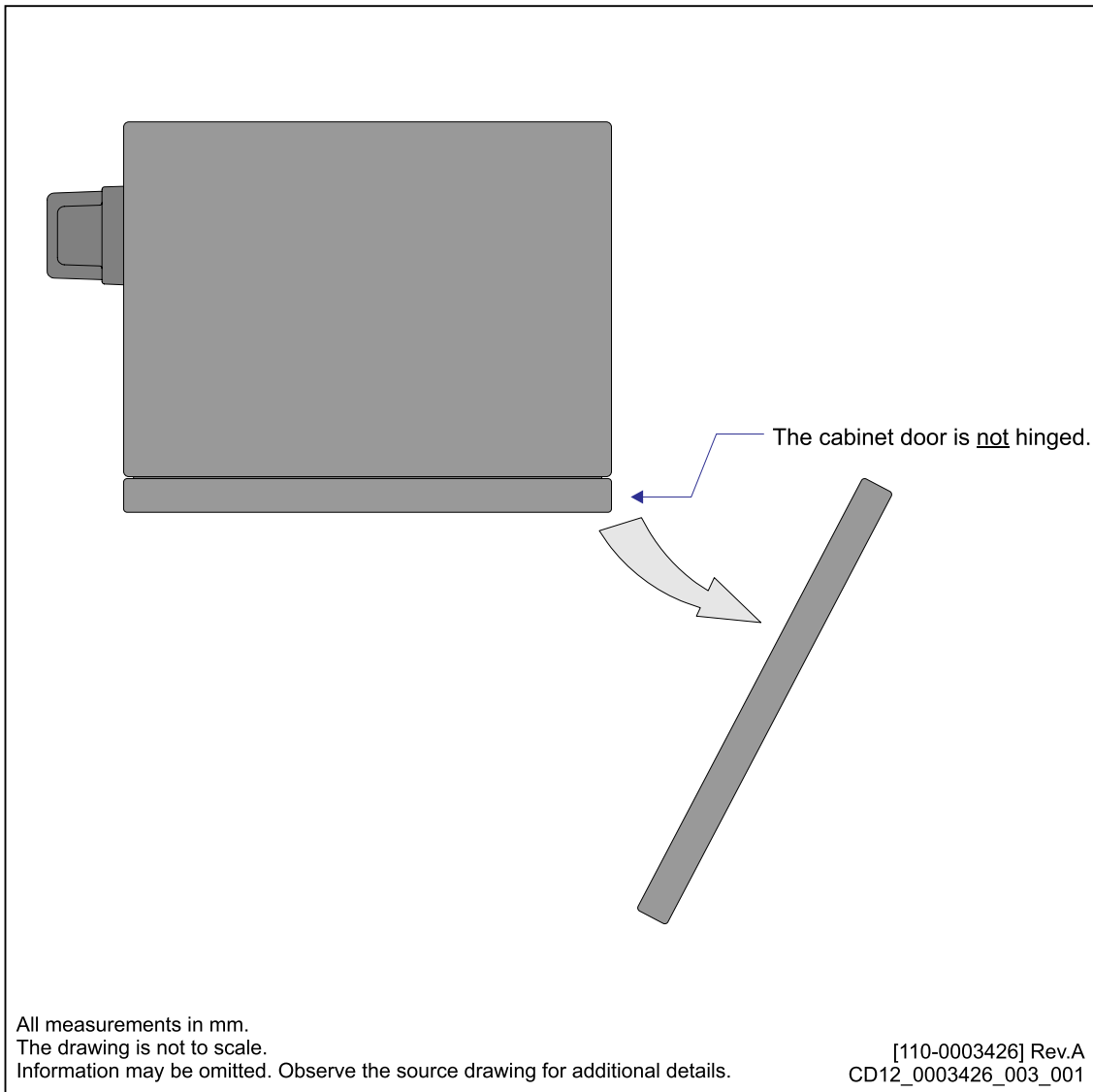

Related topics

[Drawing file, page 51](#)

328873 Transceiver dimensions (Mk1/Old)

Download the source drawing from our website: <https://www.kongsberg.com/sx90>

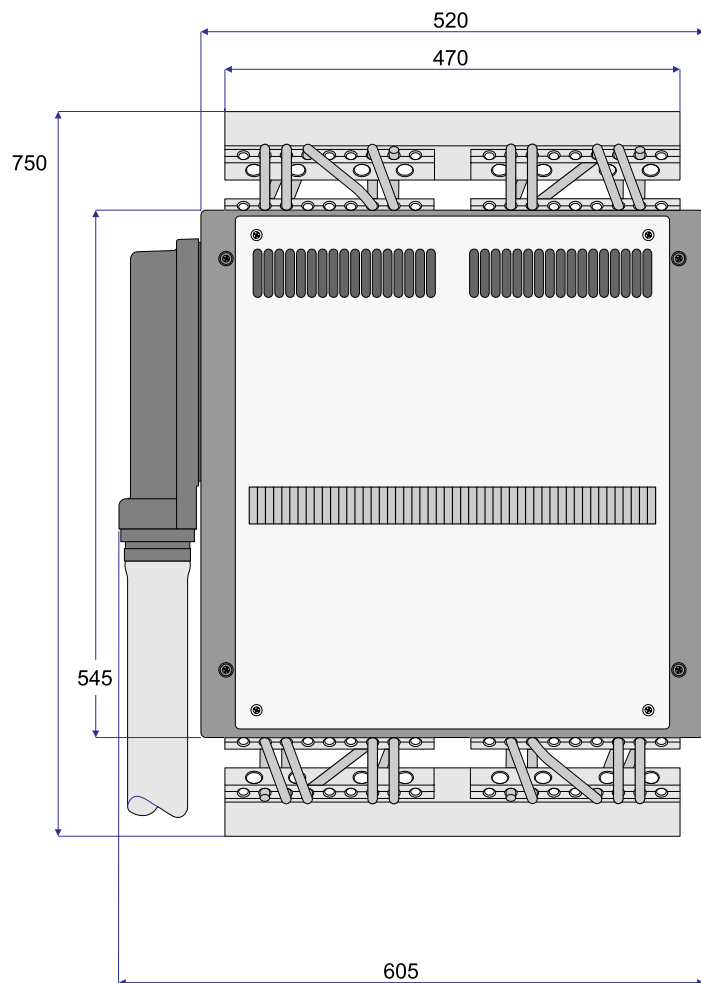

All measurements in mm.
The drawing is not to scale.
Information may be omitted. Observe the source drawing for additional details.

[328873] Rev.B
CD12_328873_001_001

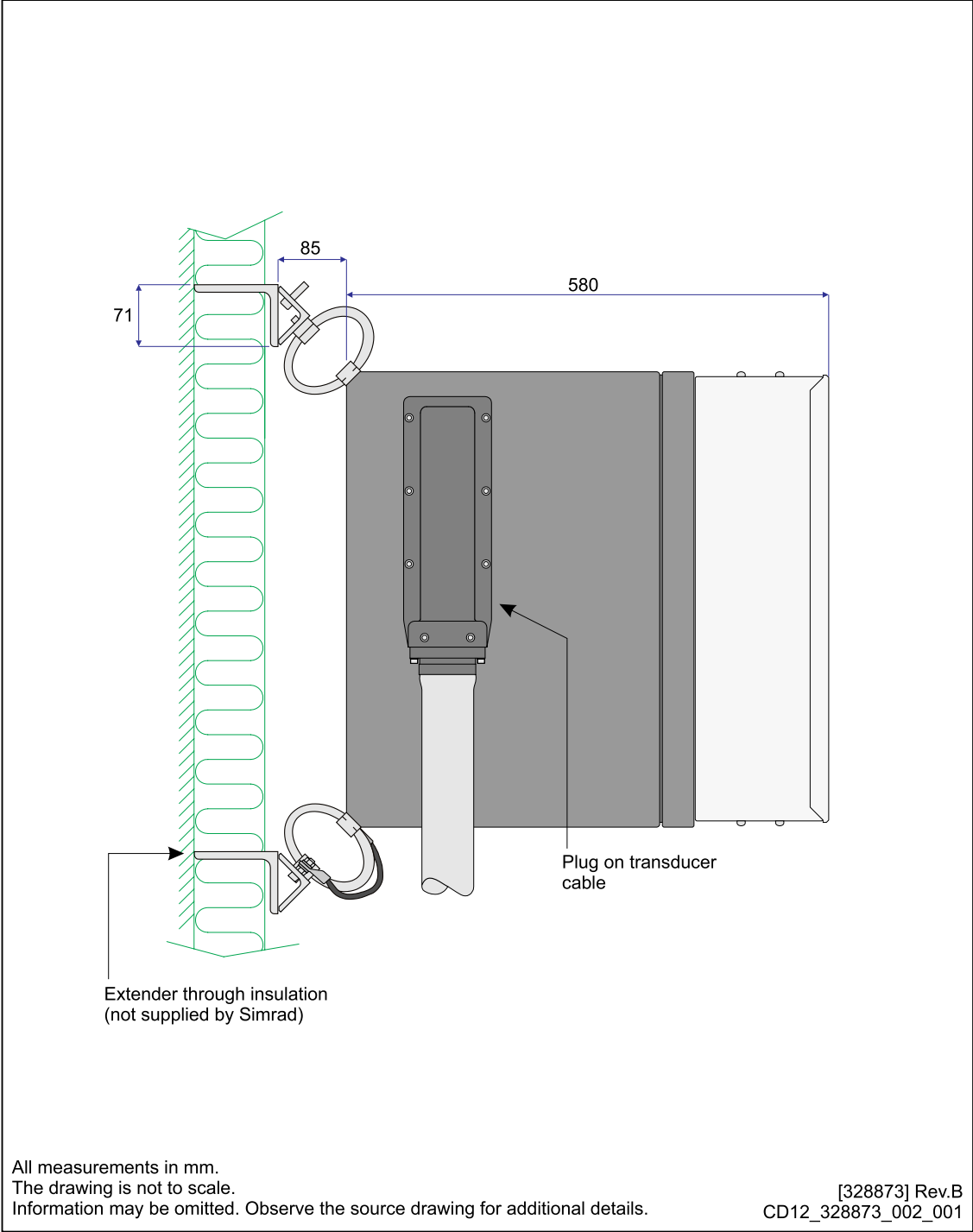

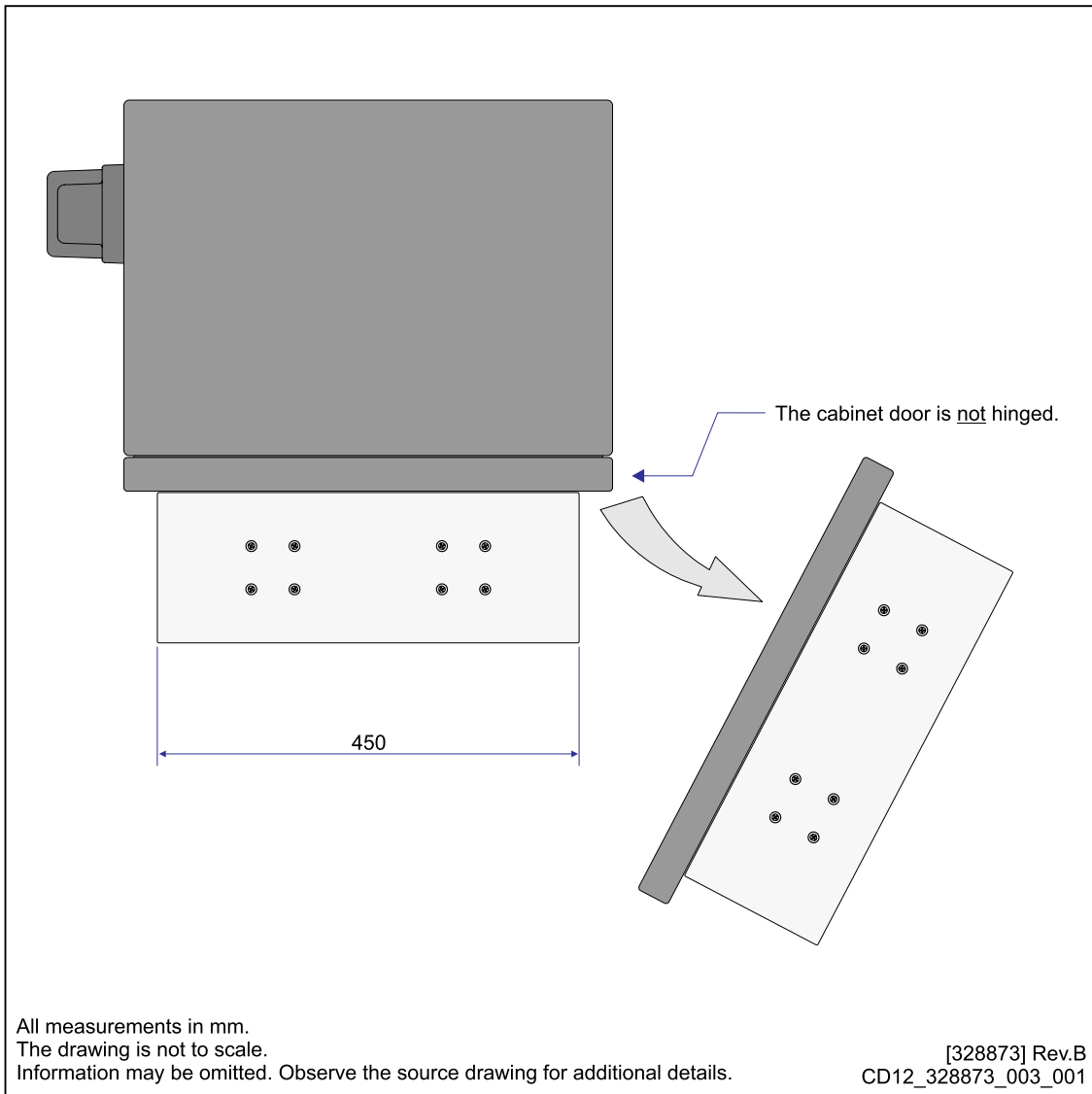

Related topics

[Drawing file, page 51](#)

280328 Hull Unit dimensions SX92

Download the source drawing from our website: <https://www.kongsberg.com/sx90>

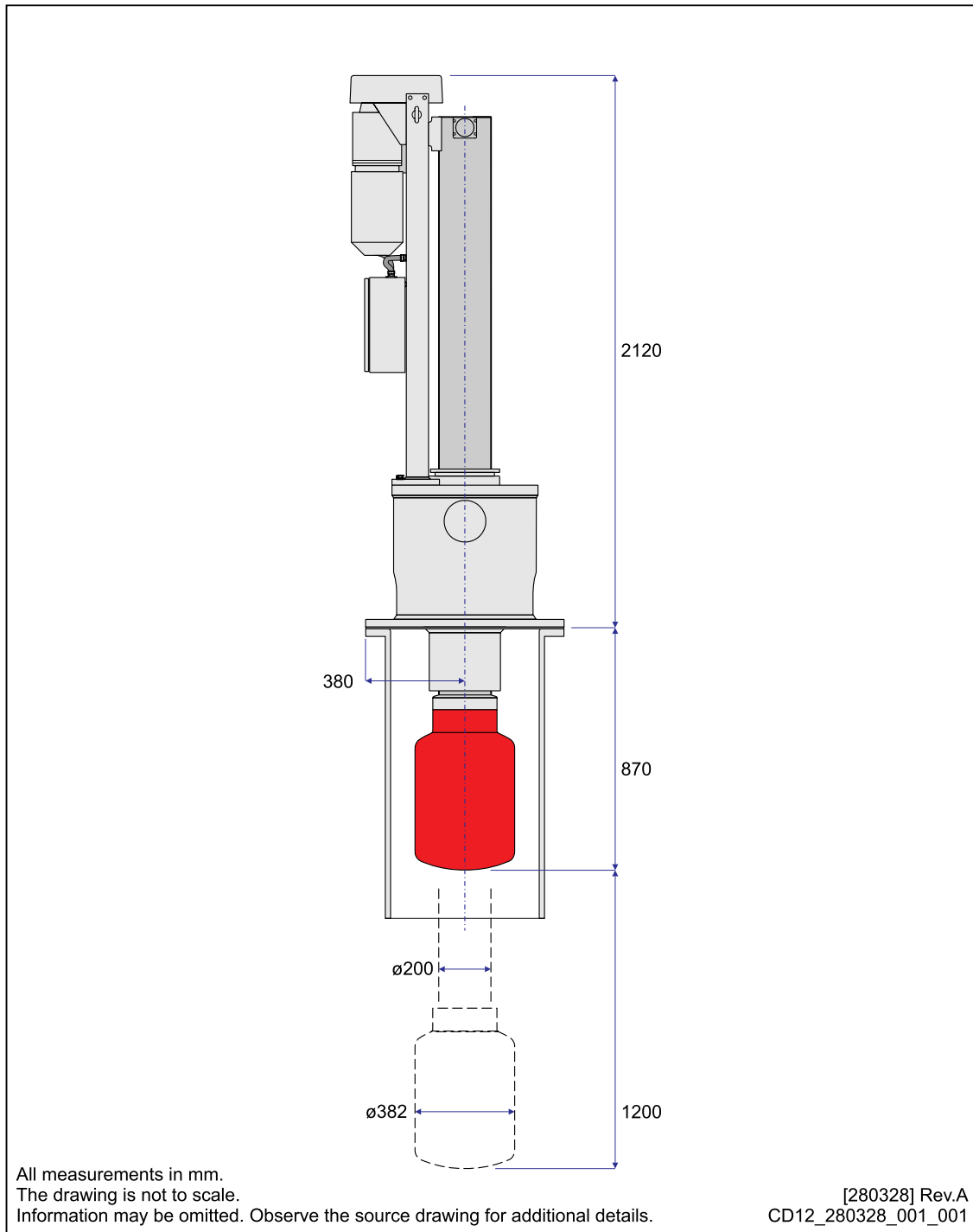

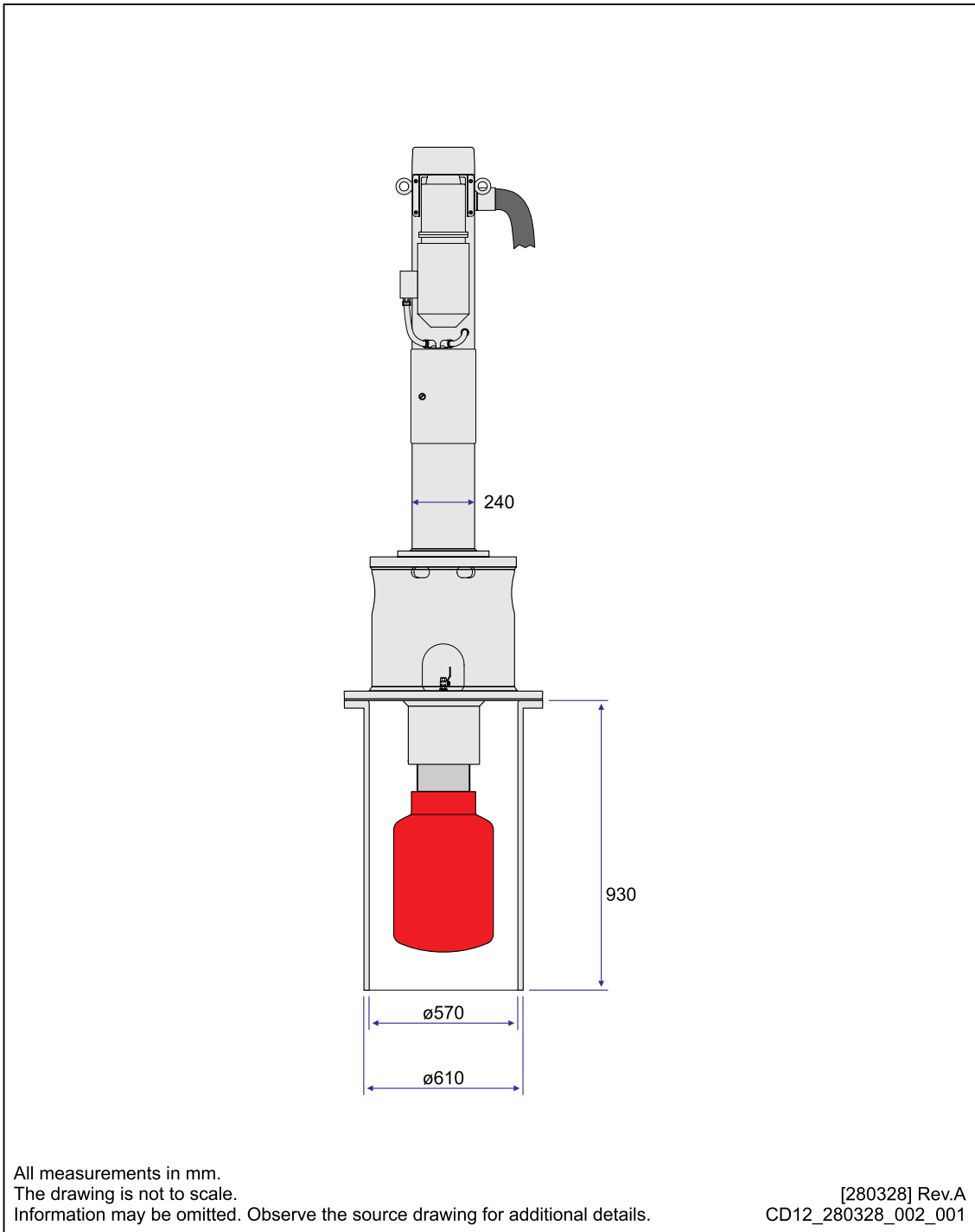

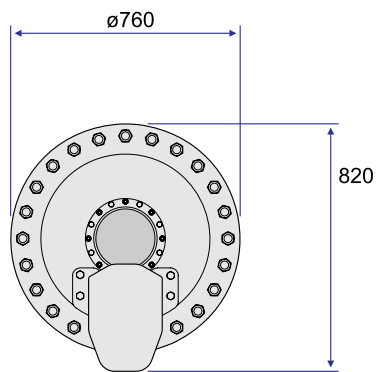

All measurements in mm.
The drawing is not in scale.
Information may be omitted. Observe the source drawing for additional details.

[280328] Rev.A
CD12_280328_003_001

Related topics

[Drawing file, page 51](#)

280328 Hull Unit dimensions SX93

Download the source drawing from our website: <https://www.kongsberg.com/sx90>

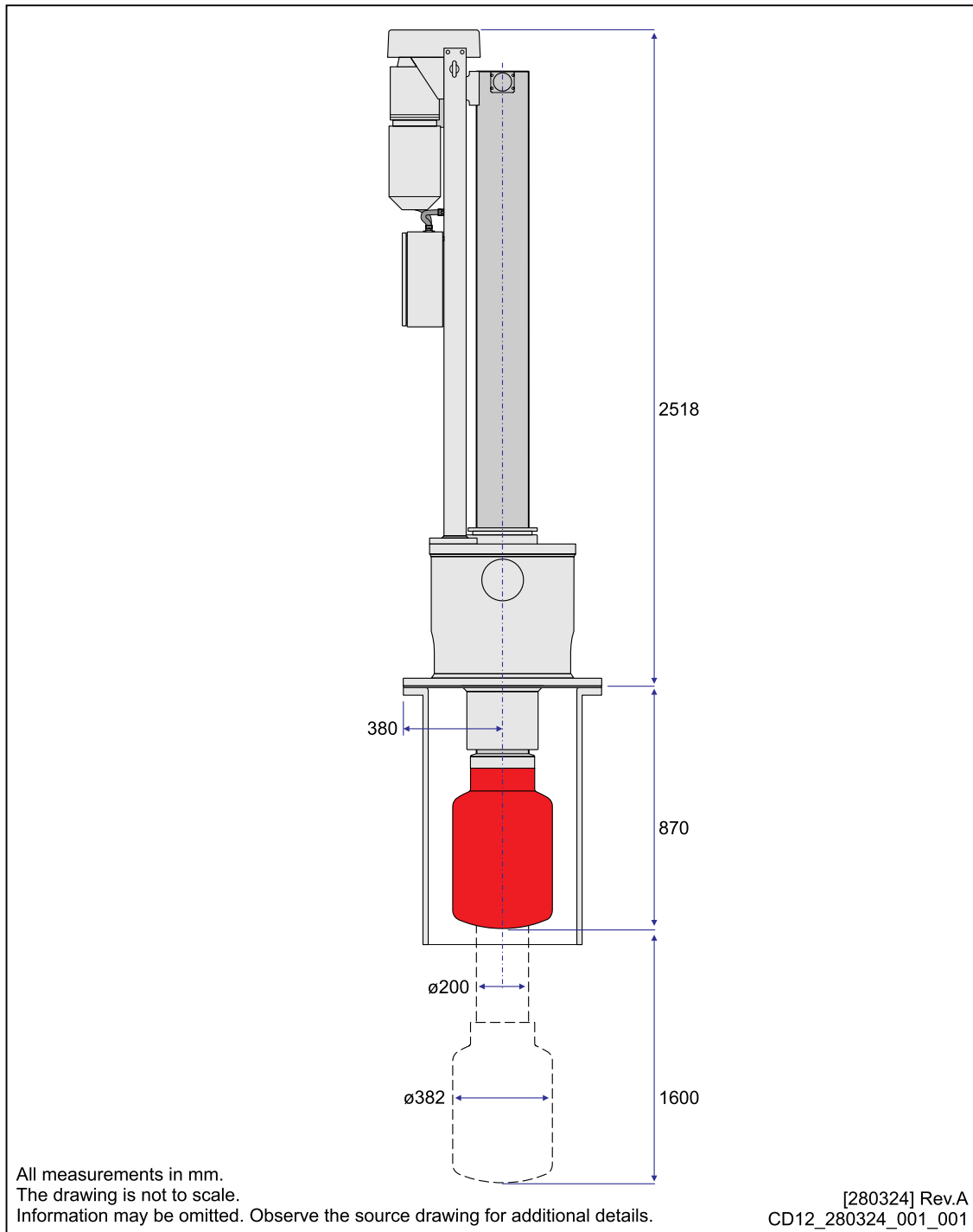

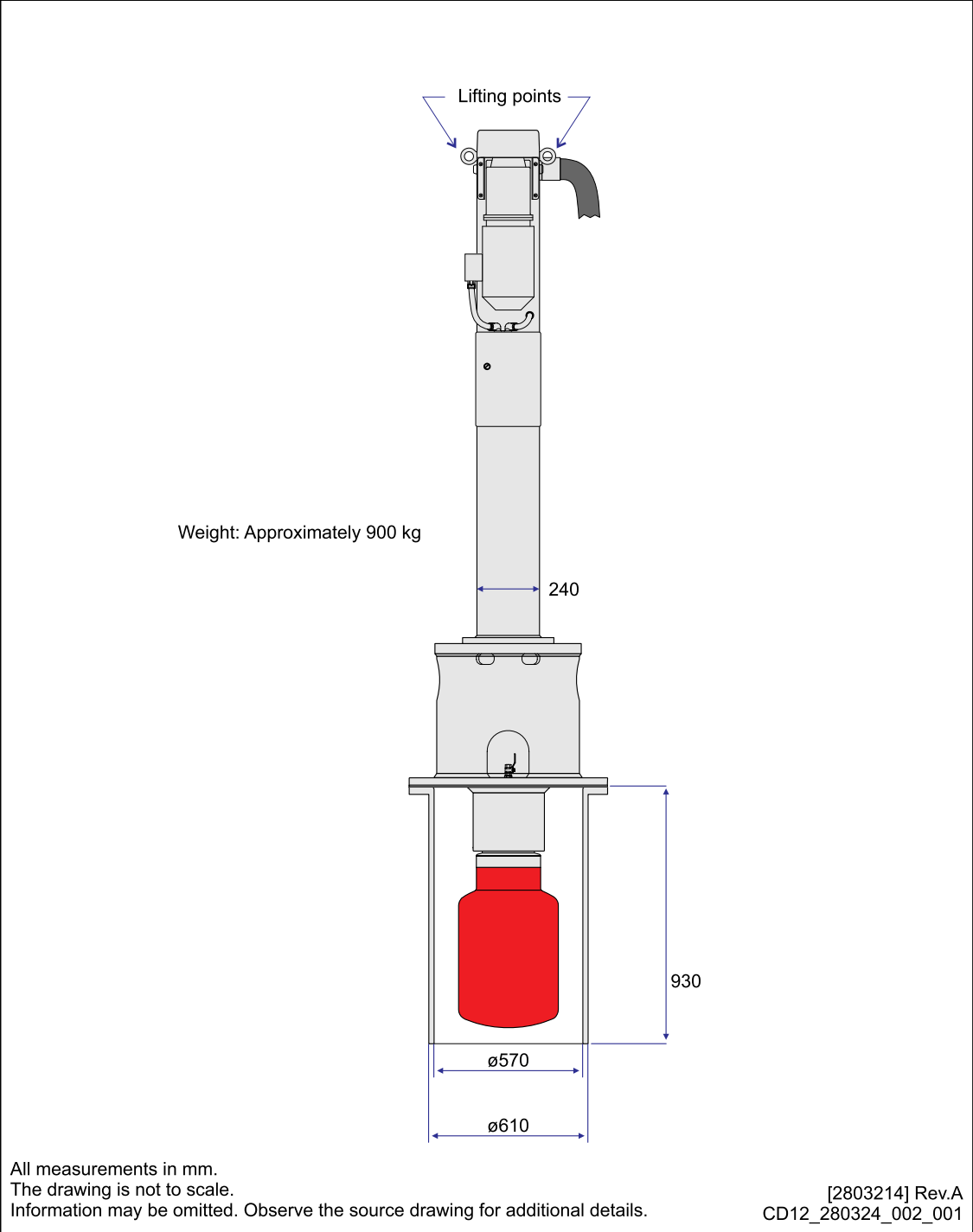

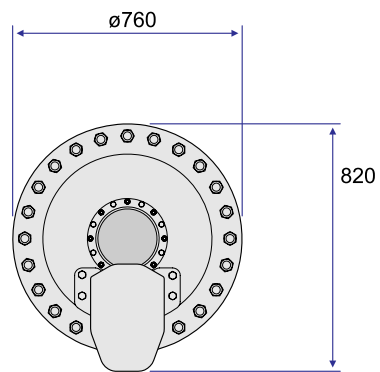

All measurements in mm.
The drawing is not to scale.
Information may be omitted. Observe the source drawing for additional details.

[280324] Rev.A
CD12_280324_003_001

Related topics

[Drawing file, page 51](#)

318900 Hull Unit dimensions SX95

Download the source drawing from our website: <https://www.kongsberg.com/sx90>

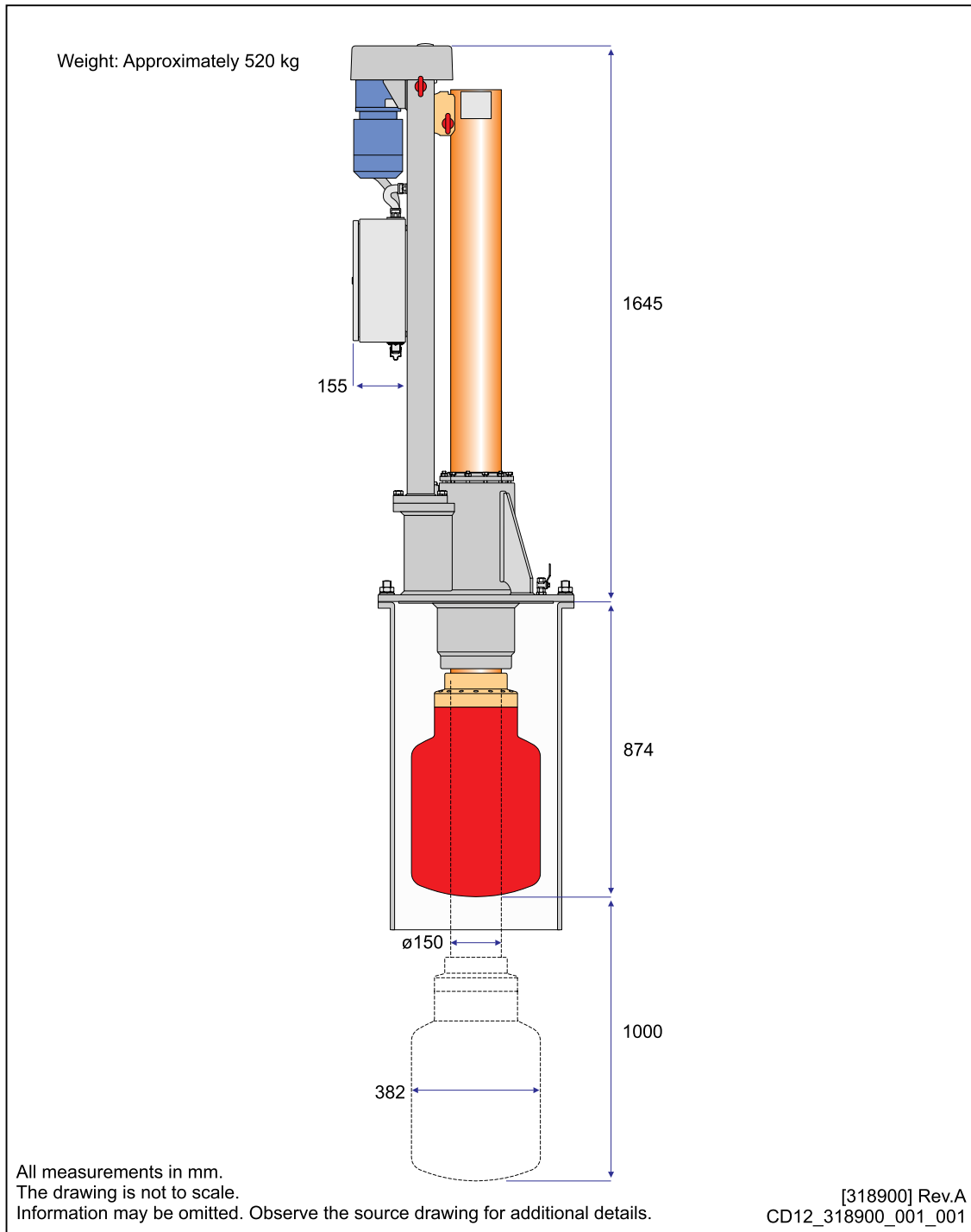

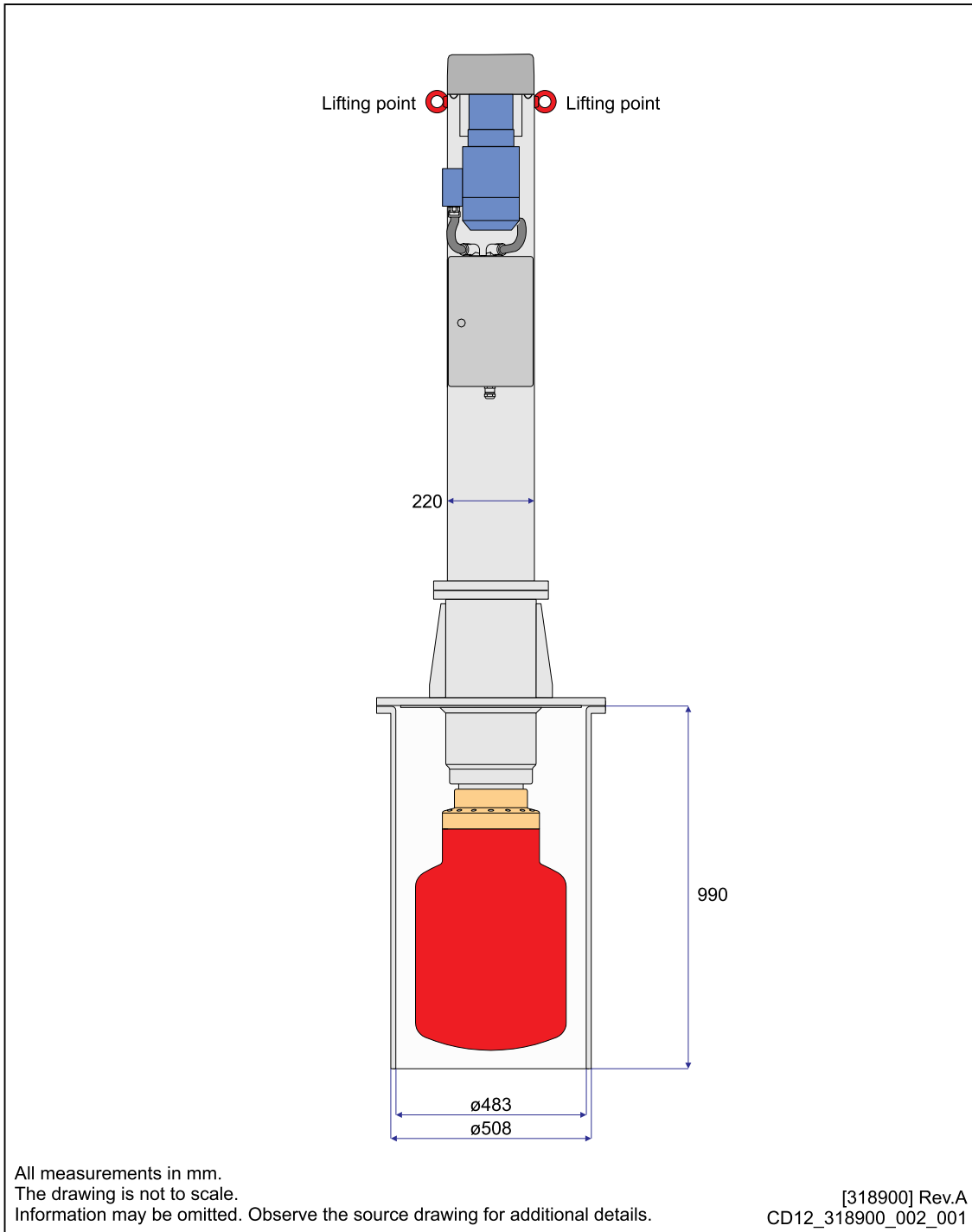

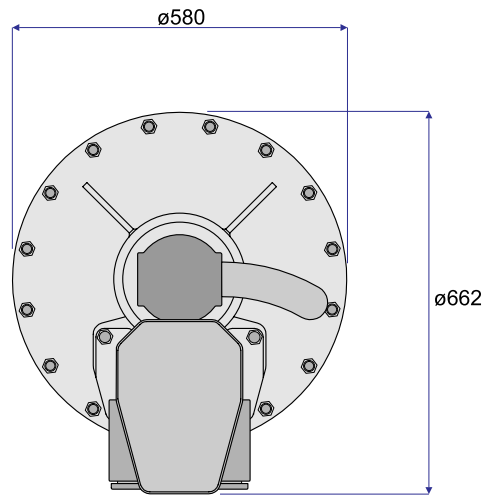

All measurements in mm.
The drawing is not to scale.
Information may be omitted. Observe the source drawing for additional details.

[318900] Rev.A
CD12_318900_003_001

Related topics

[Drawing file, page 51](#)

207481 Installation trunk dimensions SX92/SX93

Download the source drawing from our website: <https://www.kongsberg.com/sx90>

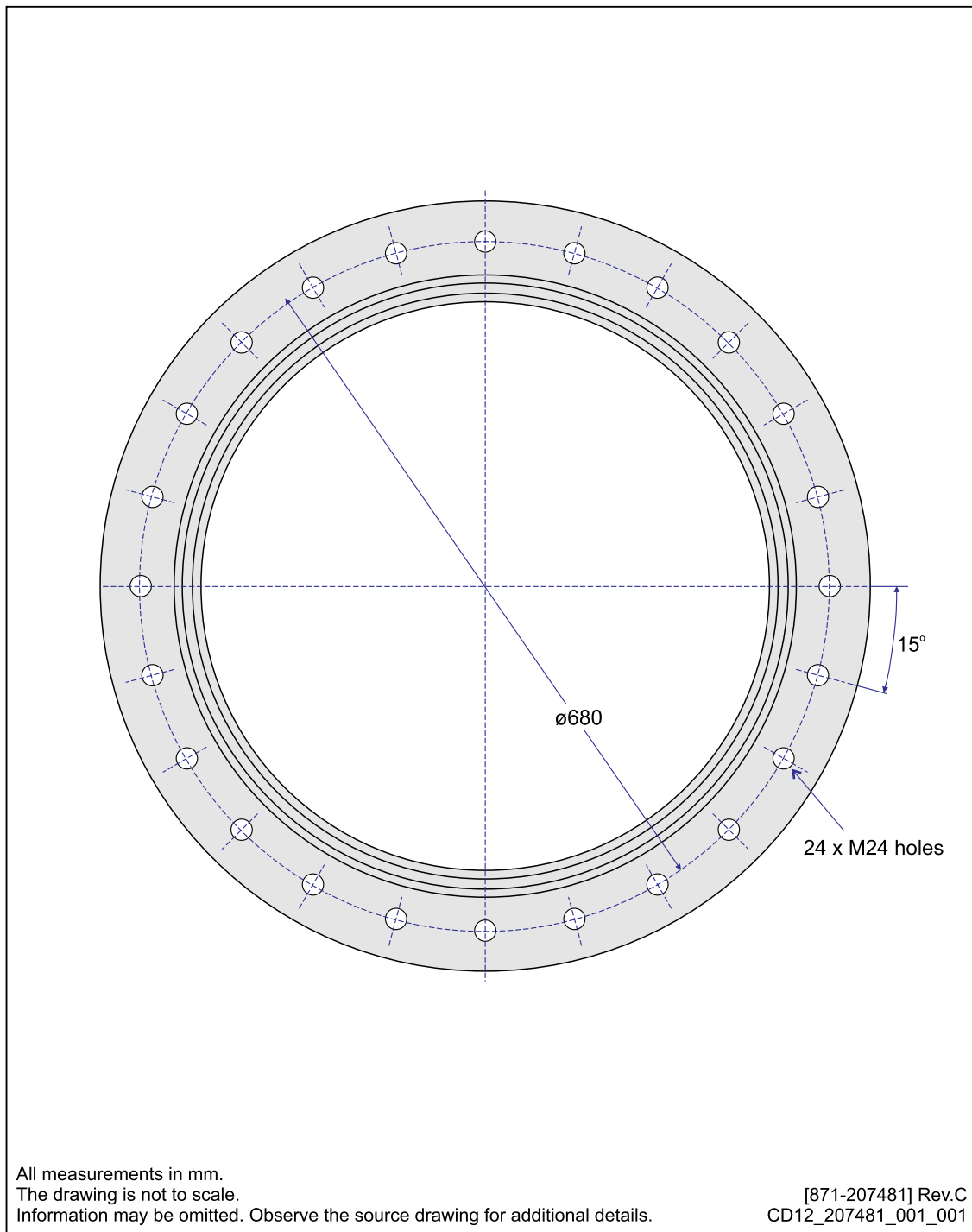

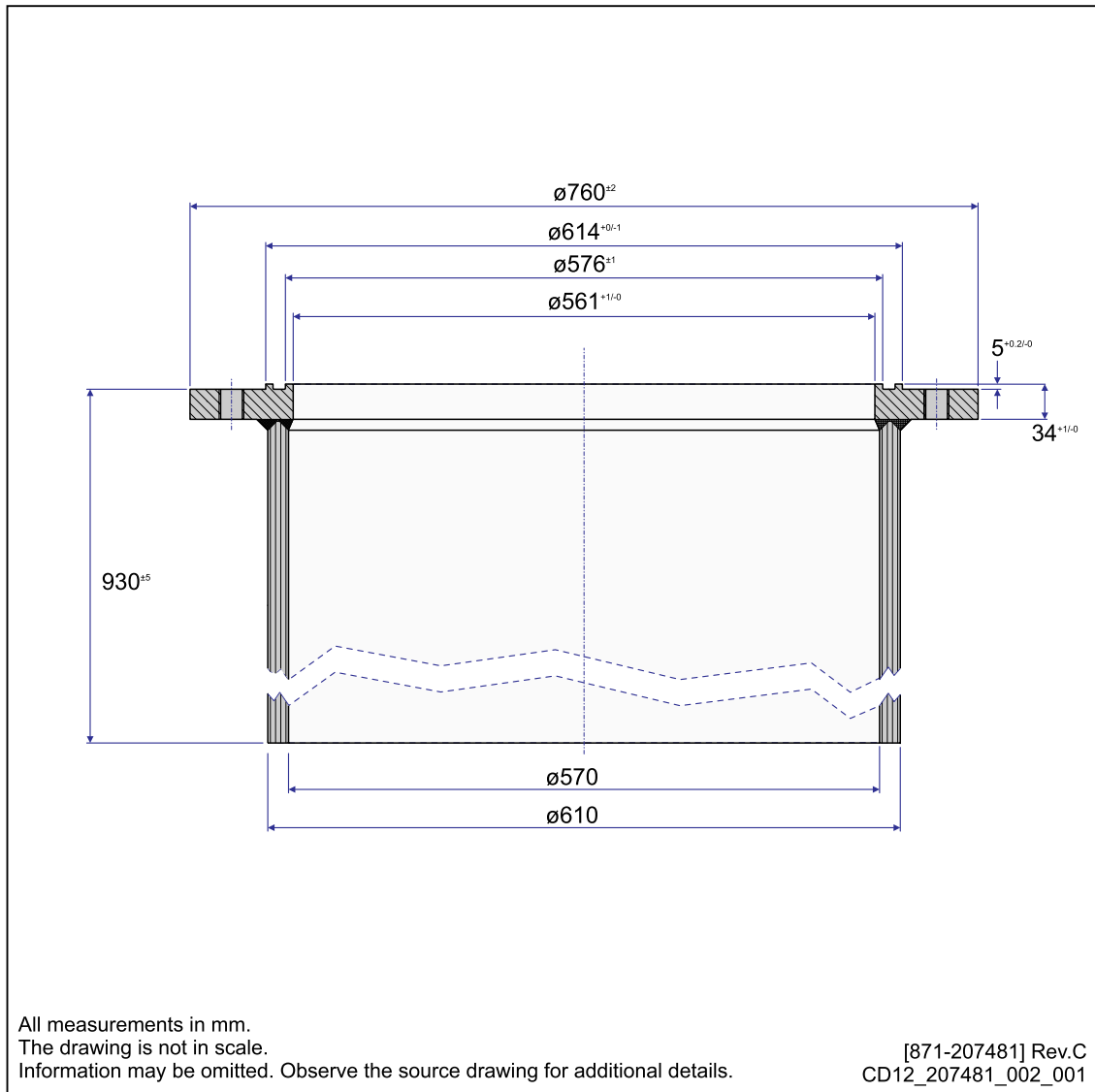

Related topics

[Drawing file, page 51](#)

322202 Installation trunk dimensions SX95

Download the source drawing from our website: <https://www.kongsberg.com/sx90>

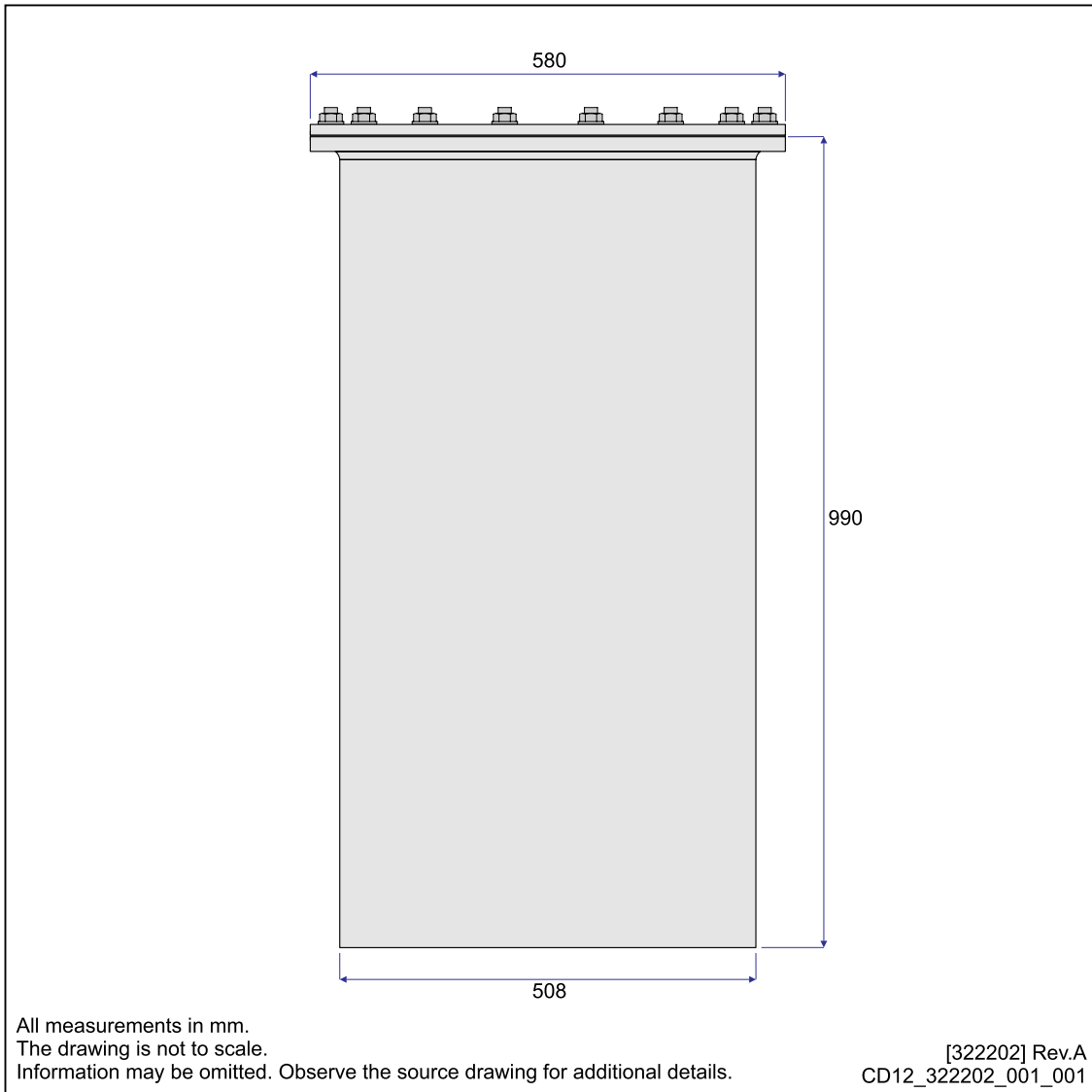

Related topics

[Drawing file, page 51](#)

113361 Installation trunk SX95

Download the source drawing from our website: <https://www.kongsberg.com/sx90>

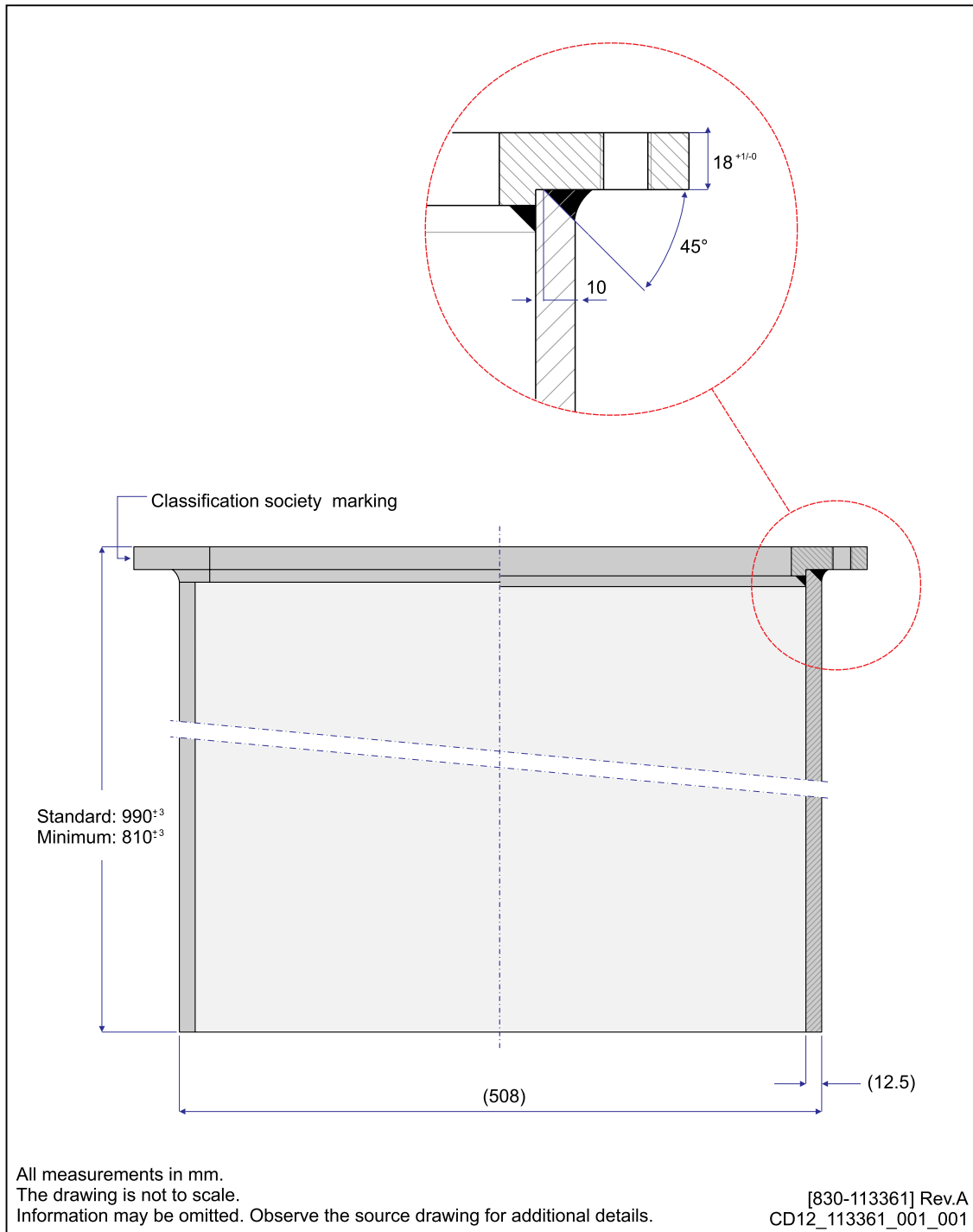

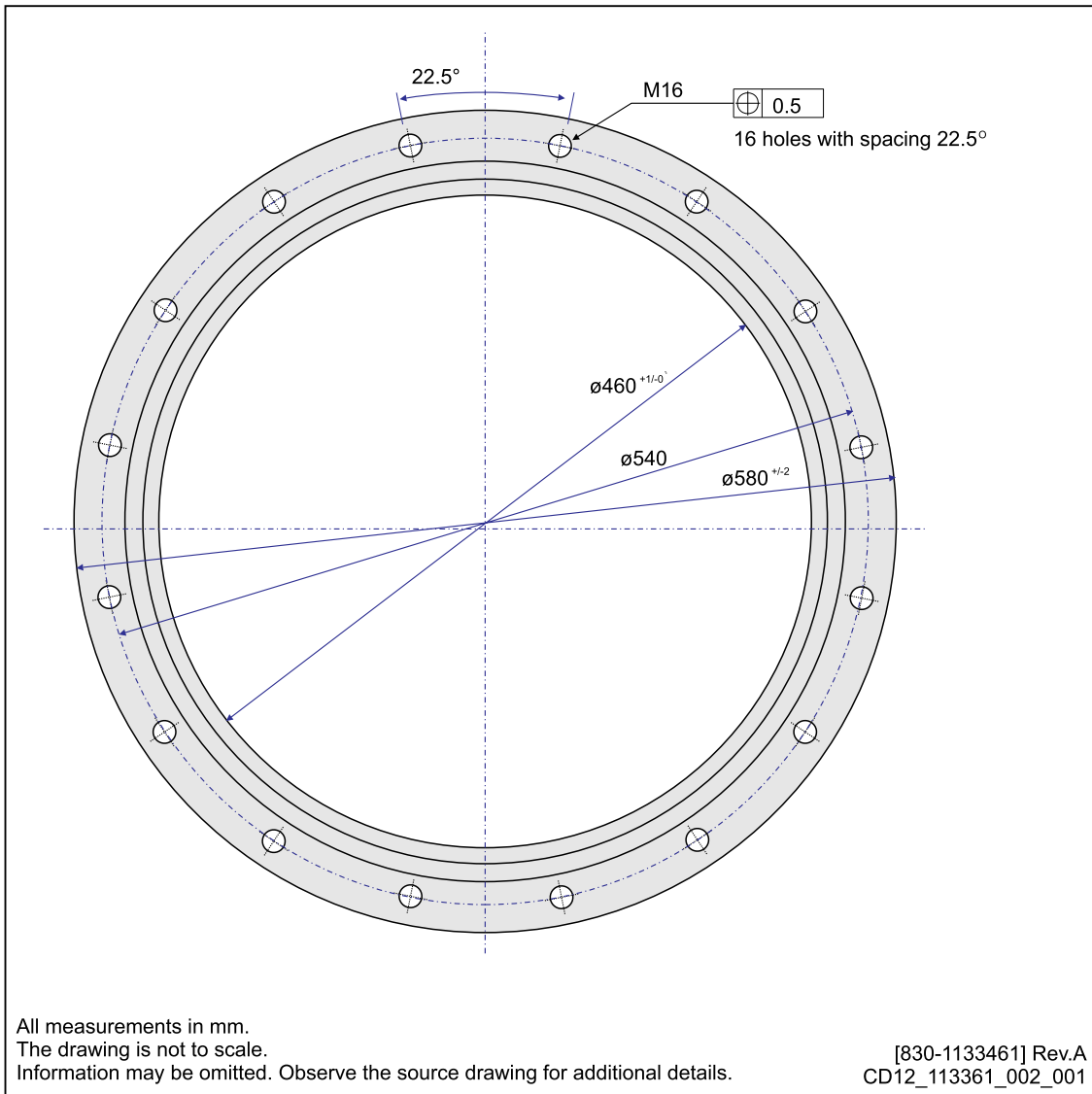

Related topics

[Drawing file, page 51](#)

207485 Blind flange dimensions (ø760 mm)

Download the source drawing from our website: <https://www.kongsberg.com/sx90>

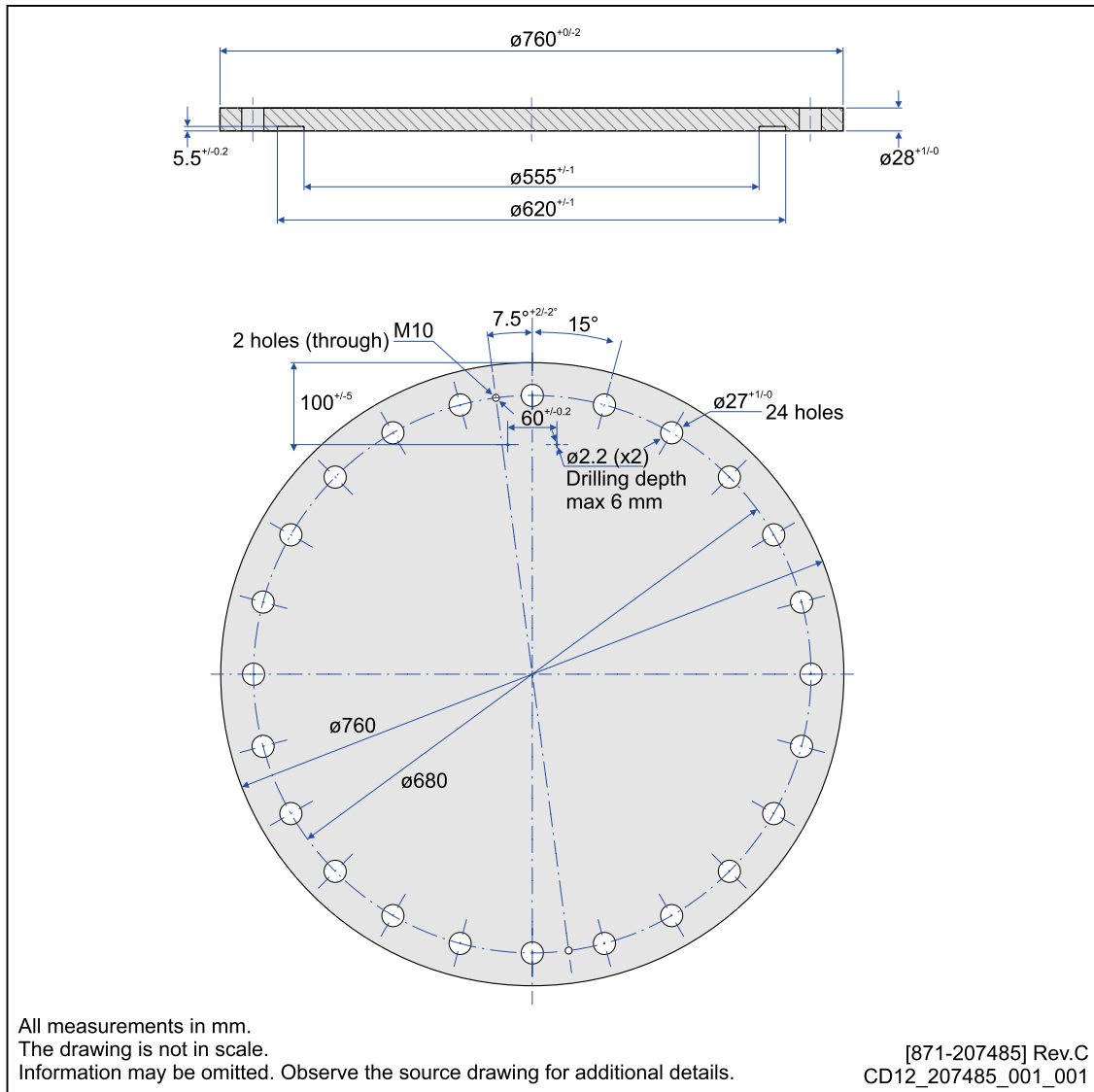

Related topics

[Drawing file, page 51](#)

113362 Blind flange dimensions (ø580 mm)

Download the source drawing from our website: <https://www.kongsberg.com/sx90>

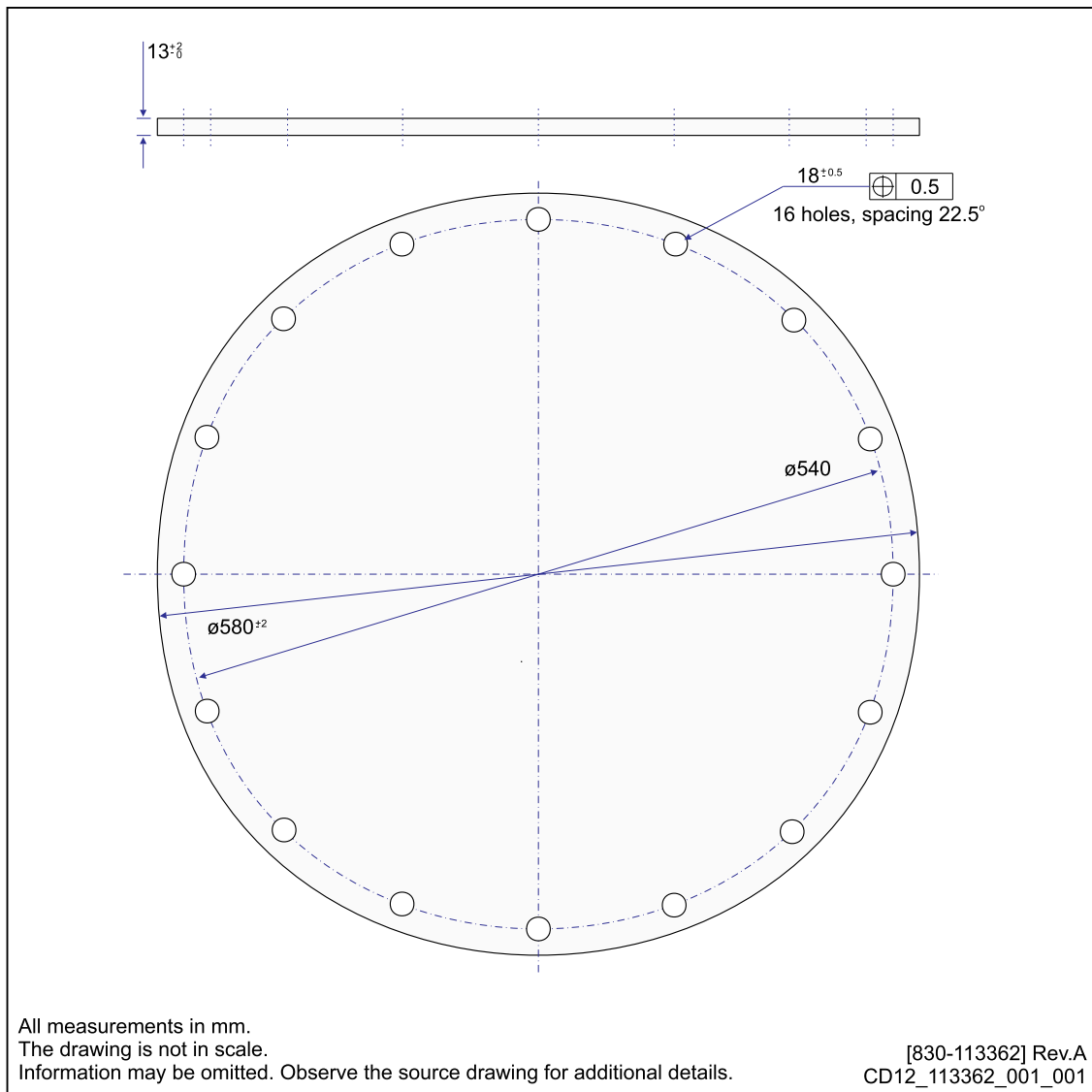

Related topics

[Drawing file, page 51](#)

082973 Mounting flange DN500

Download the source drawing from our website: <https://www.kongsberg.com/sx90>

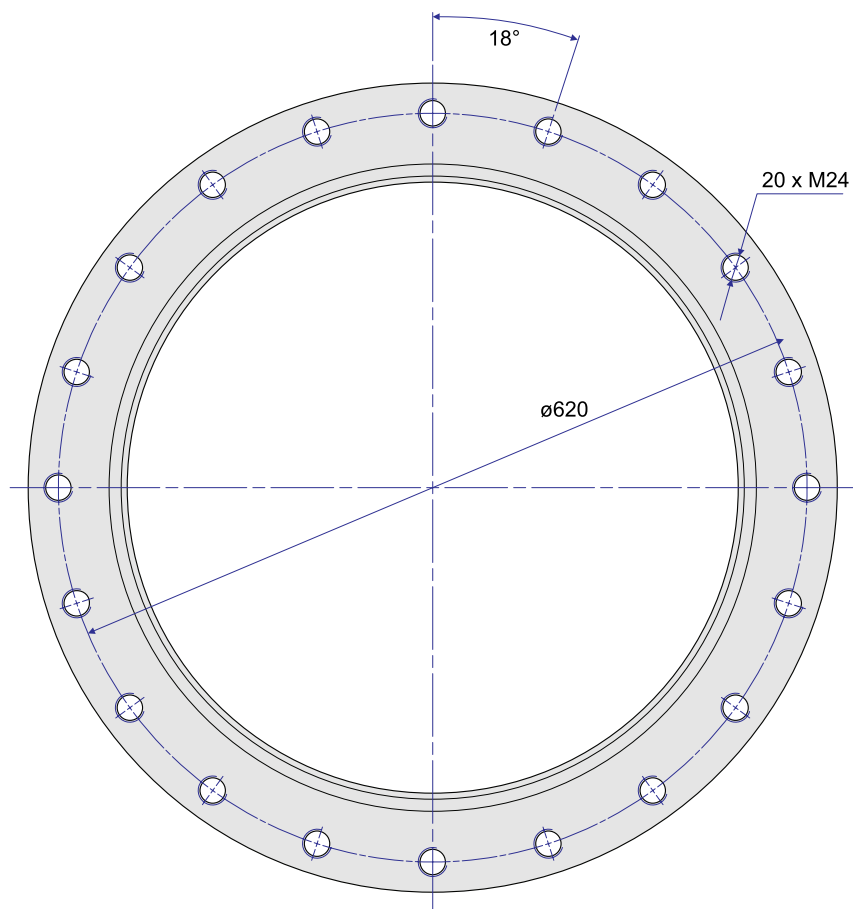

All measurements in mm.
The drawing is not to scale.
Information may be omitted. Observe the source drawing for additional details.

[082973] Rev.E01
CD12_082973_001_001

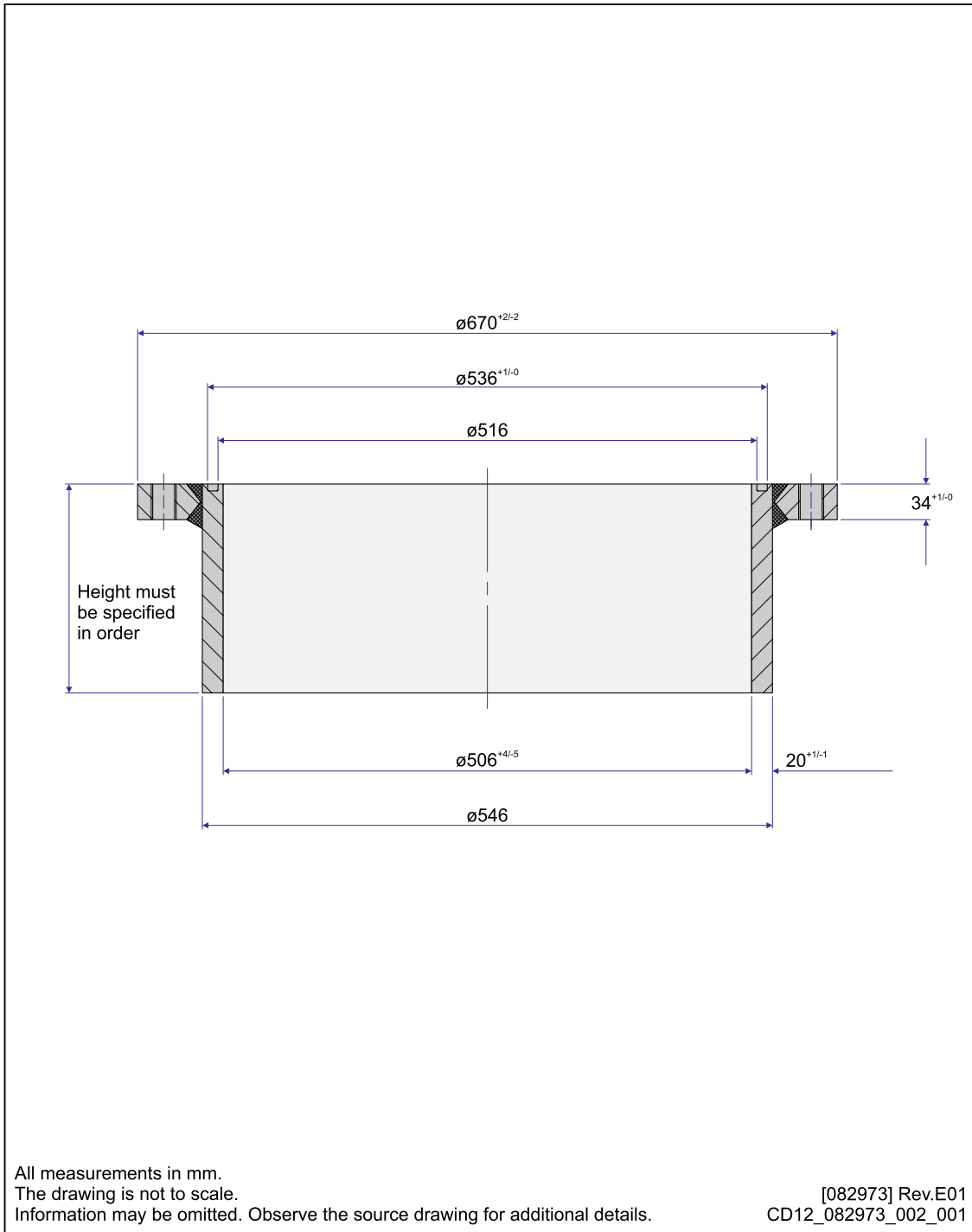

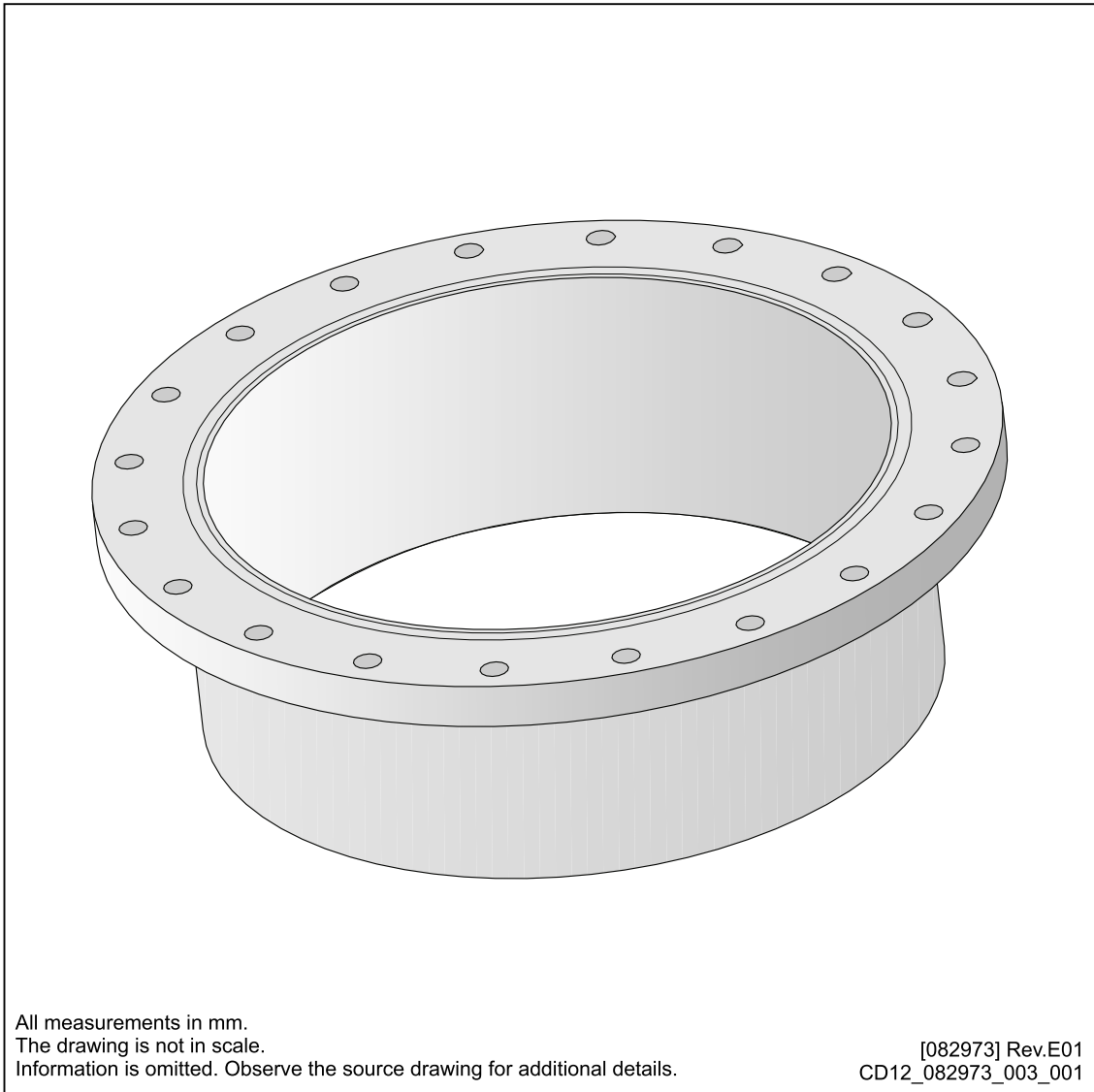

Related topics

[Drawing file, page 51](#)

083045 Gate valve installation DN500

Download the source drawing from our website: <https://www.kongsberg.com/sx90>

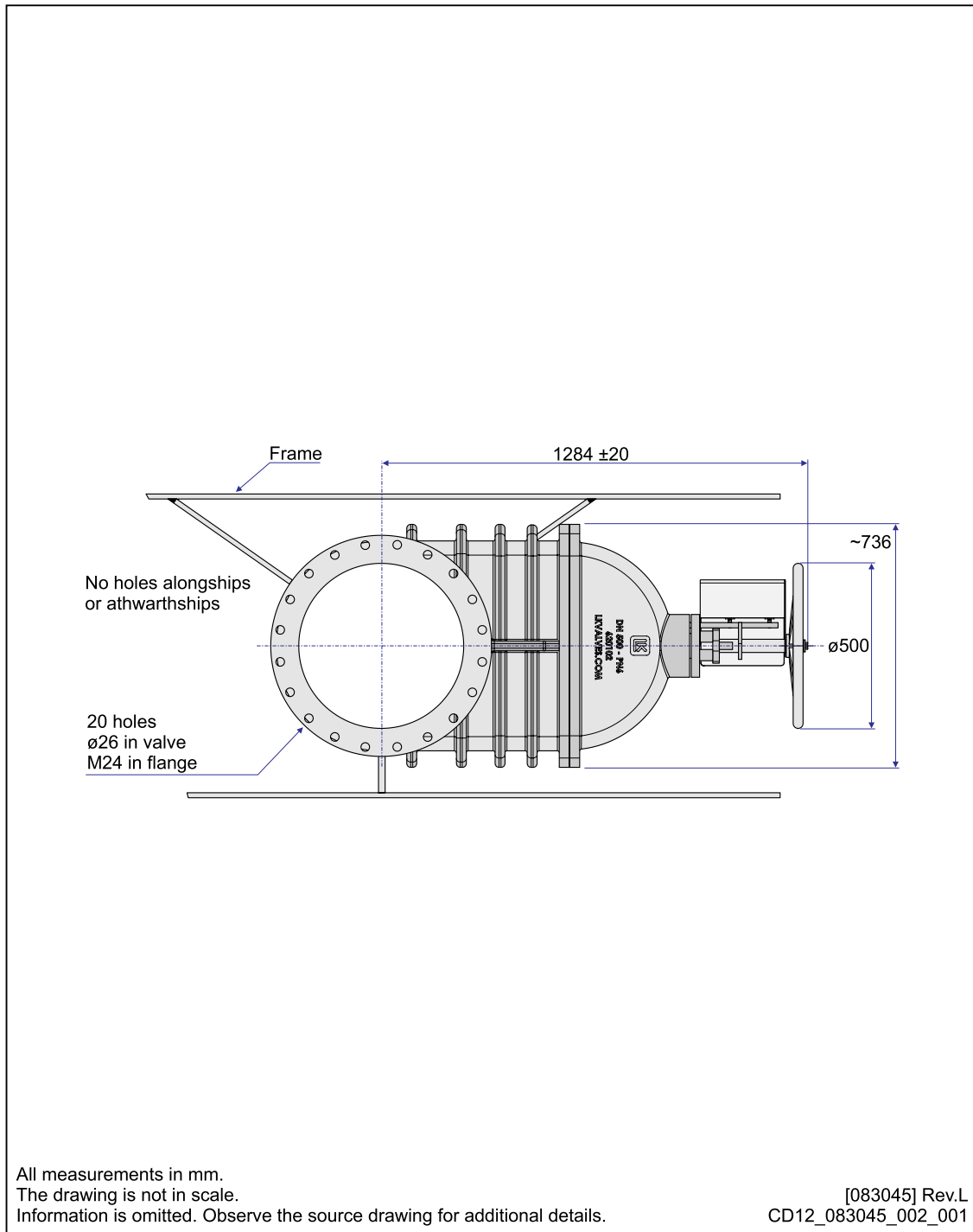

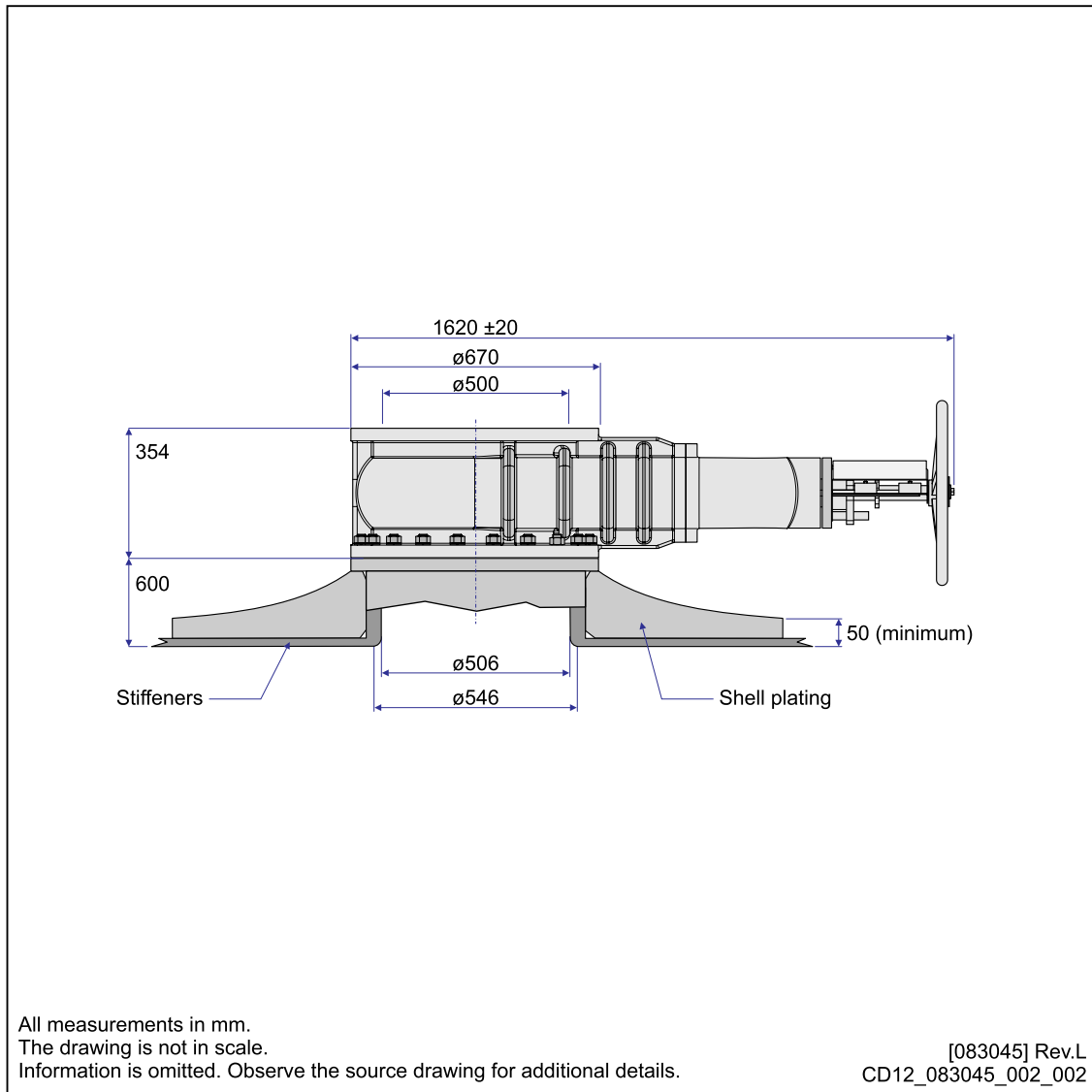

Related topics

[Drawing file, page 51](#)

33498 Gate valve dimensions DN500

To obtain the source drawing, contact the manufacturer.

NOTE:

This is a copy of the original drawing made by the manufacturer. We are not responsible for errors. Changes made by the manufacturer may not be reflected in this copy.

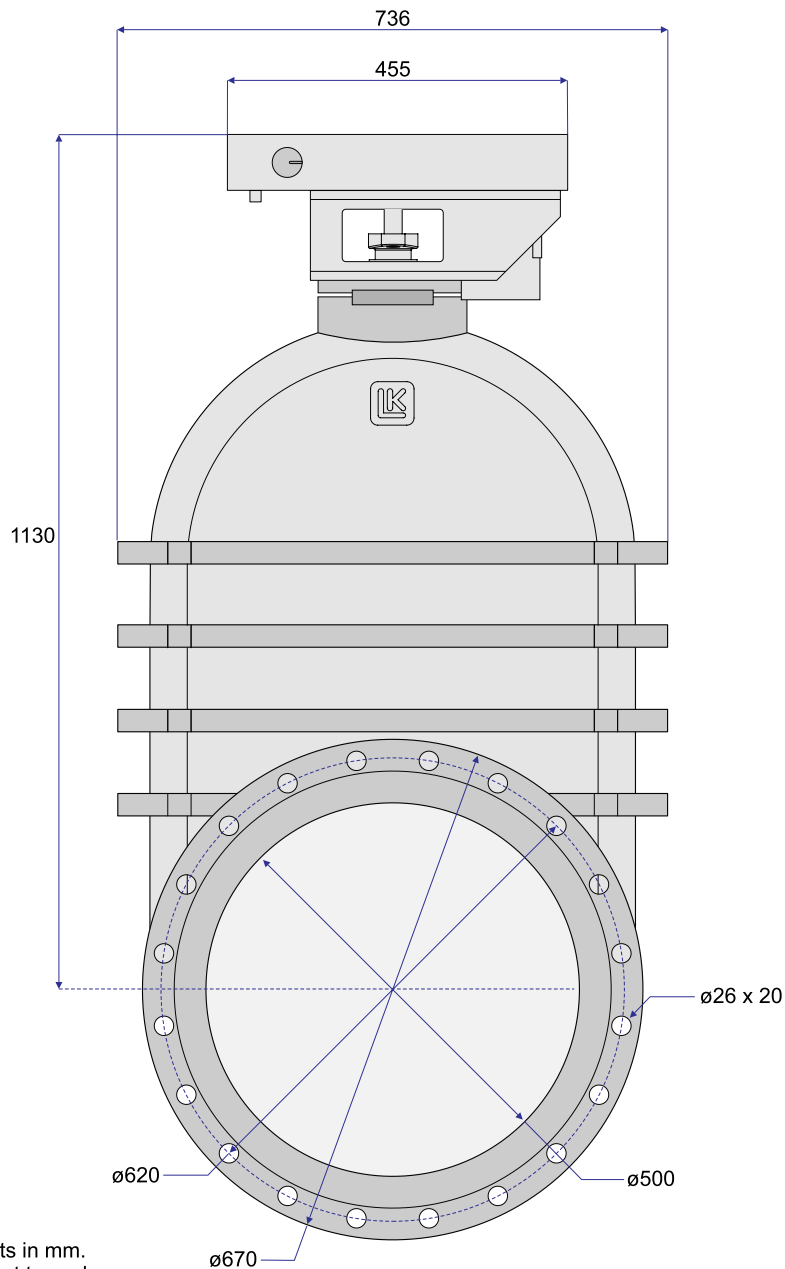

All measurements in mm.
The drawing is not to scale.
Information may be omitted. Observe the source drawing for additional details.

[33498] Rev.0
CD12_0002_020_001

NOTE:
This is a copy of the original drawing made by the manufacturer. We are not responsible for errors. Changes made by the manufacturer may not be reflected in this copy.

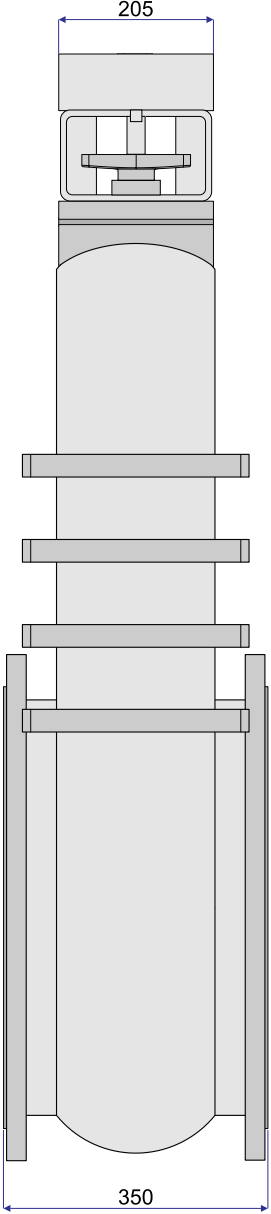

All measurements in mm.
The drawing is not to scale.
Information may be omitted. Observe the source drawing for additional details.

[33498] Rev.0
CD12_0002_021_001

NOTE:

This is a copy of the original drawing made by the manufacturer. We are not responsible for errors. Changes made by the manufacturer may not be reflected in this copy.

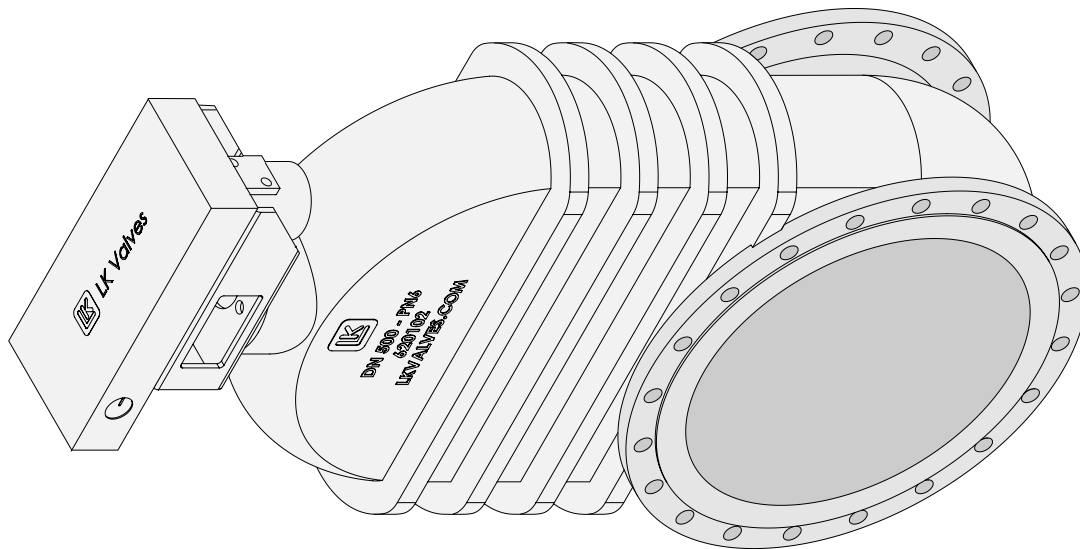

All measurements in mm.
The drawing is not in scale.
Information may be omitted. Observe the source drawing for additional details.

[33498] Rev.0
CD12_0002_022_001

Related topics

[Drawing file, page 51](#)

37357 Gate valve dimensions DN500

To obtain the source drawing, contact the manufacturer.

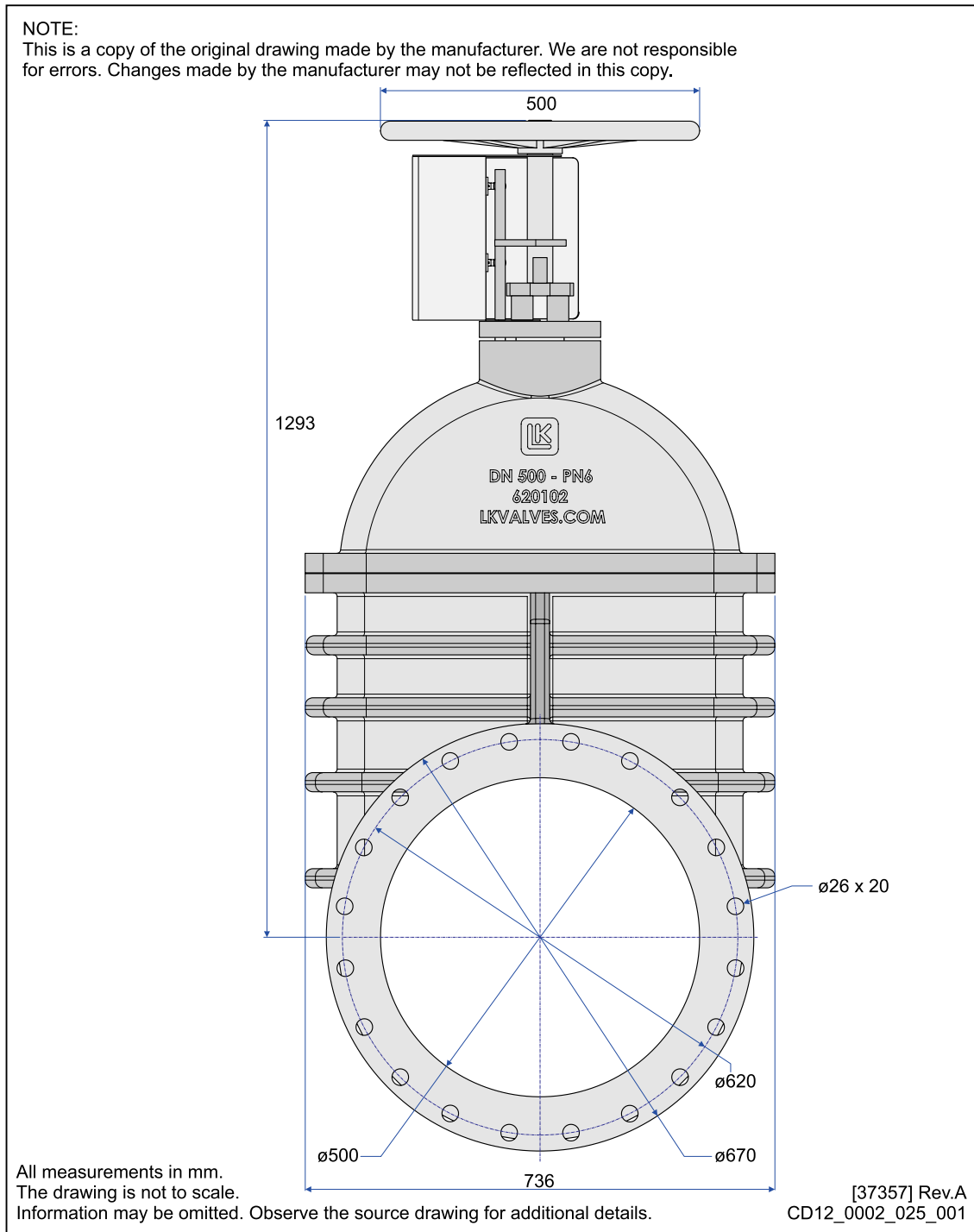

NOTE:

This is a copy of the original drawing made by the manufacturer. We are not responsible for errors. Changes made by the manufacturer may not be reflected in this copy.

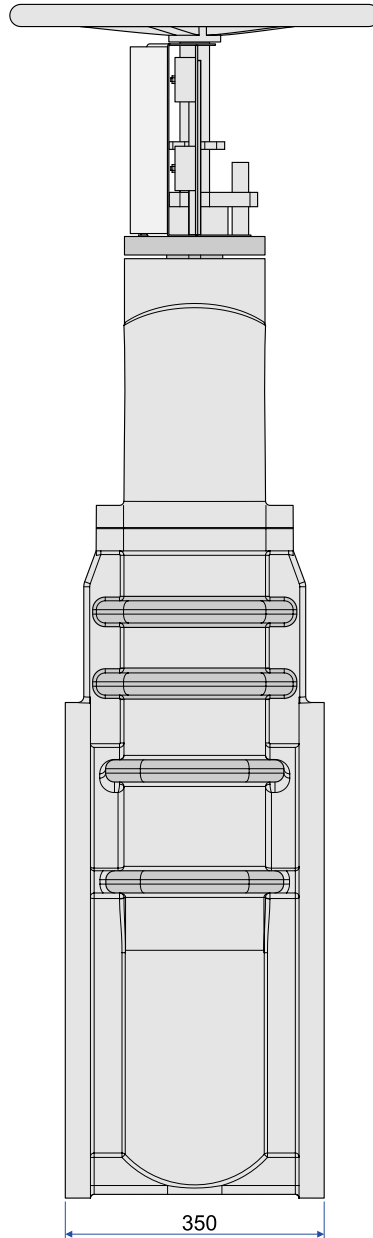

All measurements in mm.
 The drawing is not to scale.
 Information may be omitted. Observe the source drawing for additional details.

[373567] Rev.A
 CD12_0002_026_001

NOTE:

This is a copy of the original drawing made by the manufacturer. We are not responsible for errors. Changes made by the manufacturer may not be reflected in this copy.

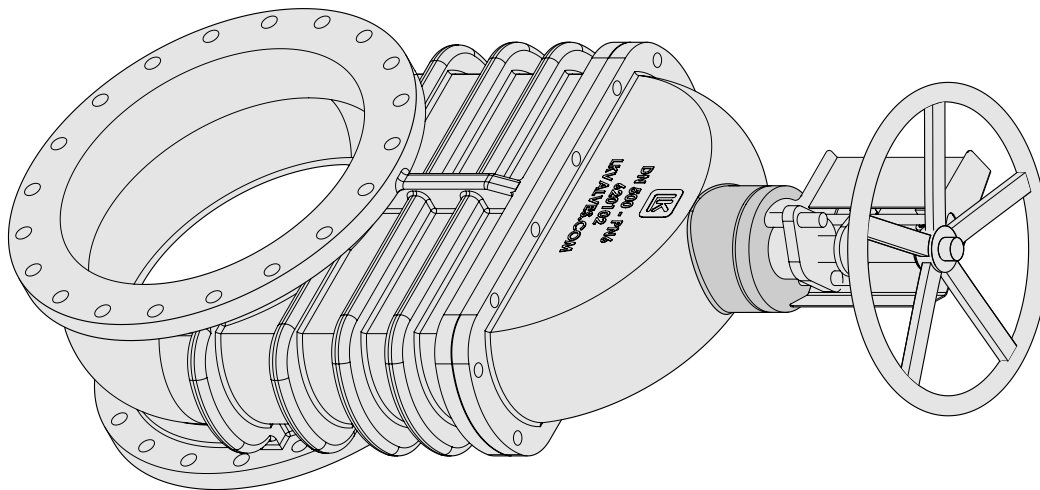

All measurements in mm.
The drawing is not in scale.
Information may be omitted. Observe the source drawing for additional details.

[37357] Rev.A
CD12_0002_027_001

Related topics

[Drawing file, page 51](#)

Datagram formats

The SX90 system can send and receive information to and from several different peripherals. All transmissions take place as *datagrams* with data sentences. Each datagram has a defined format and length.

The most common standard is NMEA 0183. The National Marine Electronics Association describes it as follows:

The NMEA 0183 Interface Standard defines electrical signal requirements, data transmission protocol and time, and specific sentence formats for a 4800-baud serial data bus. Each bus can have only one talker but many listeners.

National Marine Electronics Association

The specifications are provided in a separate publication. See our website for more information.

Tip

*The information is included in the SX90 context sensitive online help. Select **Help** on the top bar.*

Index

A	
about	
drawings.....	52
About the drawings in the drawing file	52
ac mains power	
requirements.....	38
approval	
classification society.....	29
installation drawings	52
B	
blind flange	
outline dimensions.....	94–95
C	
cables	
requirements.....	28
classification society	
approval.....	29
approval (installation drawings)	52
classification society approval	
requirements.....	29
compass	
description.....	21
required item	21
scope of supply.....	21
compass deviation	
requirements.....	28
compass safe distance	
display.....	48
technical specifications.....	48
Compass Safe Distance (CSD)	
computer.....	48
Hull Unit.....	49
Operating Panel (Mk1).....	48
Operating Panel (Mk2).....	49
Operating Panel (Mk3).....	49
Processor Unit.....	48
transceiver	49
Transceiver Unit	49
computer	
Compass Safe Distance (CSD).....	48
description.....	14
environmental requirements	45
introduction.....	14
outline dimensions.....	41, 53, 57, 60
overview	14
purpose.....	14
weight.....	41
course gyro	
description.....	21
required item	21
scope of supply.....	21
CSD	
computer.....	48
Hull Unit.....	49
Operating Panel (Mk1).....	48
Operating Panel (Mk2).....	49
Operating Panel (Mk3).....	49
Processor Unit.....	48
transceiver	49
Transceiver Unit	49
Operating Panel (Mk3).....	49
Processor Unit.....	48
transceiver	49
Transceiver Unit	49
CSD (compass safe distance)	
technical specifications.....	48
CSD (Compass Safe Distance)	
display.....	48
D	
datagram formatsdescription	107
description	
compass.....	21
computer.....	14
course gyro	21
datagram formats	107
display.....	13
Global Positioning System (GPS)	22
gyro compass.....	21
heading sensor.....	21
Hull Unit.....	16
installation trunk	20
Installation trunk	18
Operating Panel.....	22
Processor Unit.....	14
speed log	21
system	10
Transceiver Unit	15
Transducer	17
uninterruptible power supply.....	21
UPS.....	21
diagram	
system	12
dimensions	
blind flange	94–95
computer.....	41, 53, 57, 60
display.....	41
Enix.....	53
gate valve DN500.....	99, 101, 104
HT20470 (AC version).....	60
HT20470 (DC version).....	57
Hull Unit.....	43
hull unit SX92.....	80
hull unit SX93.....	83
hull unit SX95.....	86
installation trunk SX92/SX93	89
installation trunk SX95	91–92
mounting flange DN500	96
Operating Panel (Mk1).....	42, 63
Operating Panel (Mk2).....	42, 65
Operating Panel (Mk3).....	42, 71
Operating Panel adapter plate (Mk2).....	69
Operating Panel cut-out (Mk2)	68
Processor Unit.....	41, 53, 57, 60
technical specifications.....	41
transceiver	43
Transceiver Unit	43, 74, 77
display	
compass safe distance	48

- description 13
 - dimensions 41
 - environmental requirements 45
 - minimum requirements 50
 - outline dimensions 41
 - power requirements 38
 - weight 41
 - display power requirements 38
 - DN500 gate valve
 - dimensions 99, 101, 104
 - DN500 mounting flange
 - outline dimensions 96
 - docking
 - requirements 29
 - drawing
 - blind flange 94–95
 - computer 53, 57, 60
 - display outline dimensions 41
 - Enix 53
 - gate valve DN500 99, 101, 104
 - HT20470 (AC version) 60
 - HT20470 (DC version) 57
 - hull unit SX92 80
 - hull unit SX93 83
 - hull unit SX95 86
 - installation trunk SX92/SX93 89
 - installation trunk SX95 91–92
 - mounting flange DN500 96
 - Operating Panel (Mk1) 63
 - Operating Panel (Mk2) 65
 - Operating Panel (Mk3) 71
 - Operating Panel adapter plate (Mk2) 69
 - Operating Panel cut-out (Mk2) 68
 - Processor Unit 53, 57, 60
 - Transceiver Unit 74, 77
 - drawings
 - about 52
 - approval 52
 - dry docking
 - requirements 29
- E**
- Enix
 - dimensions 41
 - environmental requirements 45
 - outline dimensions 53
 - weight 41
 - Enix Processor Unit environmental requirements 45
 - Enix Processor Unit weight and outline dimensions 41
 - environmental requirements
 - computer 45
 - display 45
 - Hull Unit 47
 - Operating Panel (Mk1) 46
 - Operating Panel (Mk2) 46
 - Operating Panel (Mk3) 46
 - Processor Unit 45
 - technical specifications 45
 - transceiver 47
 - Transceiver Unit 47
- G**
- gate valve DN500
 - dimensions 99, 101, 104
 - outline dimensions 99, 101, 104
 - general safety rules 25
 - Global Positioning System (GPS)
 - description 22
 - optional item 22
 - scope of supply 22
 - GPS (Global Positioning System)
 - description 22
 - optional item 22
 - scope of supply 22
 - gyro compass
 - description 21
 - required item 21
 - scope of supply 21
- H**
- heading sensor
 - description 21
 - required item 21
 - scope of supply 21
 - help
 - support 30
 - technical support 30
 - high voltage
 - safety rules 25
 - HT20470 (AC version)
 - outline dimensions 60
 - HT20470 (DC version)
 - outline dimensions 57
 - Hull Unit
 - Compass Safe Distance (CSD) 49
 - description 16
 - environmental requirements 47
 - outline dimensions 43
 - power consumption 40
 - power requirements 40
 - weight 43
 - Hull Unit compass safe distance 49
 - Hull Unit environmental requirements 47
 - Hull Unit power requirements 40
 - hull unit SX92
 - dimensions 80
 - outline dimensions 80
 - hull unit SX93
 - dimensions 83
 - outline dimensions 83
 - hull unit SX95
 - dimensions 86
 - outline dimensions 86
 - Hull Unit weight and outline dimensions 43
- I**
- important 8
 - Before you turn on the SX90 system 8
 - If something breaks down 8
 - Manual operation of the hull unit 8
 - Watertight integrity 8
 - When the SX90 system is not used 8
 - When you are docking your vessel 8

When you want to turn off the SX90 system.....	8	technical support.....	30
information		Operating Panel	
support.....	30	description.....	22
technical support.....	30	optional item.....	22
installation drawings		scope of supply.....	22
about.....	52	supported.....	22
approval.....	52	Operating Panel (Mk1)	
installation trunk		Compass Safe Distance (CSD).....	48
description.....	20	environmental requirements.....	46
required item.....	20	outline dimensions.....	42, 63
scope of supply.....	20	power consumption.....	38
Installation trunk		power requirements.....	38
description.....	18	weight.....	42
installation trunk SX92/SX93		Operating Panel (Mk2)	
outline dimensions.....	89	Compass Safe Distance (CSD).....	49
installation trunk SX95		environmental requirements.....	46
outline dimensions.....	91–92	Operating Panel cut-out drawing.....	68
internet		outline dimensions.....	42, 65
network security.....	29	power consumption.....	39
introduction		power requirements.....	39
computer.....	14	weight.....	42
Processor Unit.....	14	Operating Panel (Mk3)	
technical specifications.....	34	Compass Safe Distance (CSD).....	49
Introduction to technical specifications.....	34	environmental requirements.....	46
		outline dimensions.....	42, 71
		power requirements.....	39
		weight (Mk3).....	42
		Operating Panel adapter plate (Mk2)	
		outline dimensions.....	69
		Operating Panel compass safe distance (Mk1).....	48
		Operating Panel compass safe distance (Mk2).....	49
		Operating Panel compass safe distance (Mk3).....	49
		Operating Panel cut-out (Mk2)	
		outline dimensions.....	68
		Operating Panel environmental requirements	
		(Mk1).....	46
		Operating Panel environmental requirements	
		(Mk2).....	46
		Operating Panel environmental requirements	
		(Mk3).....	46
		Operating Panel power requirements (Mk1).....	38
		Operating Panel power requirements (Mk2).....	39
		Operating Panel power requirements (Mk3).....	39
		Operating Panel weight and outline dimensions	
		(Mk1).....	42
		Operating Panel weight and outline dimensions	
		(Mk2).....	42
		Operating Panel weight and outline dimensions	
		(Mk3).....	42
		operating voltage	
		Hull Unit.....	40
		Operating Panel (Mk1).....	38
		Operating Panel (Mk2).....	39
		Operating Panel (Mk3).....	39
		transceiver.....	39
		Transceiver Unit.....	39
		optional item	
		Global Positioning System (GPS).....	22
		Operating Panel.....	22
		Order information.....	24
		outline dimensions	
		about.....	52
		blind flange.....	94–95
		computer.....	41, 53, 57, 60
		display.....	41
K			
Kongsberg Maritime			
support.....	30		
L			
LCD display			
power requirements.....	38		
LCD monitor			
environmental requirements.....	45		
power requirements.....	38		
M			
mains power			
requirements.....	38		
maritime authority			
approval (installation drawings).....	52		
mechanical drawings			
about.....	52		
minimum requirements			
display.....	50		
monitor			
environmental requirements.....	45		
power requirements.....	38		
mounting flange DN500			
outline dimensions.....	96		
N			
network security.....	29		
Noise sources			
requirements.....	28		
O			
offices			
support.....	30		

- DN500..... 99, 101, 104
 Enix 53
 gate valve DN500..... 99, 101, 104
 HT20470 (AC version)..... 60
 HT20470 (DC version)..... 57
 Hull Unit 43
 hull unit SX92..... 80
 hull unit SX93..... 83
 hull unit SX95..... 86
 installation trunk SX92/SX93..... 89
 installation trunk SX95..... 91–92
 mounting flange DN500..... 96
 Operating Panel (Mk1)..... 42, 63
 Operating Panel (Mk2)..... 42, 65
 Operating Panel (Mk3)..... 42, 71
 Operating Panel adapter plate (Mk2)..... 69
 Operating Panel cut-out (Mk2)..... 68
 Processor Unit..... 41, 53, 57, 60
 SX92..... 80
 SX93..... 83
 SX95..... 86
 technical specifications..... 41
 transceiver 43
 Transceiver Unit 43, 74, 77
- overview
 computer 14
 Processor Unit..... 14
- P**
- performance
 specifications 34
- power
 requirements 38
- power consumption
 Hull Unit 40
 Operating Panel (Mk1)..... 38
 Operating Panel (Mk2)..... 39
 transceiver 39
 Transceiver Unit 39
- power requirements
 display..... 38
 Hull Unit 40
 Operating Panel (Mk1)..... 38
 Operating Panel (Mk2)..... 39
 Operating Panel (Mk3)..... 39
 transceiver 39
 Transceiver Unit 39
- Processor Unit
 Compass Safe Distance (CSD)..... 48
 description 14
 environmental requirements..... 45
 introduction..... 14
 outline dimensions..... 41, 53, 57, 60
 overview 14
 purpose 14
 weight 41
- purpose
 computer 14
 Processor Unit..... 14
- R**
- required item
 compass 21
- course gyro 21
 gyro compass 21
 heading sensor 21
 installation trunk 20
 speed log 21
 uninterruptible power supply..... 21
 UPS 21
- requirements
 ac mains power..... 38
 classification society approval 29
 compass deviation 28
 dry docking 29
 mains power 38
 Noise sources..... 28
 power 38
 supply power 38
 supply voltage 27
 uninterruptible power supply..... 27
 requirementscables 28
 requirementswiring 28
- S**
- safety rules
 high voltage..... 25
- scope of supply..... 23
 compass 21
 course gyro 21
 Global Positioning System (GPS) 22
 gyro compass 21
 heading sensor..... 21
 installation trunk 20
 Operating Panel 22
 speed log 21
 uninterruptible power supply..... 21
 UPS 21
- security
 network..... 29
- Simrad
 support 30
- size
 blind flange 94–95
 computer 41, 53, 57, 60
 display 41
 Enix..... 53
 gate valve DN500..... 99, 101, 104
 HT20470 (AC version)..... 60
 HT20470 (DC version)..... 57
 Hull Unit 43
 hull unit SX92..... 80
 hull unit SX93..... 83
 hull unit SX95..... 86
 installation trunk SX92/SX93..... 89
 installation trunk SX95..... 91–92
 mounting flange DN500..... 96
 Operating Panel (Mk1)..... 42, 63
 Operating Panel (Mk2)..... 42, 65
 Operating Panel (Mk3)..... 42, 71
 Operating Panel adapter plate (Mk2)..... 69
 Operating Panel cut-out (Mk2)..... 68
 Processor Unit..... 41, 53, 57, 60
 technical specifications..... 41
 transceiver 43
 Transceiver Unit 43, 74, 77
- specifications

compass safe distance	48	outline dimensions.....	43, 74, 77
environmental requirements.....	45	power consumption.....	39
outline dimensions.....	41	power requirements.....	39
performance	34	weight	43
specifications		Transceiver Unit compass safe distance	49
weight	41	Transceiver Unit environmental requirements.....	47
speed log		Transceiver Unit power requirements.....	39
description	21	Transceiver Unit weight and outline	
required item	21	dimensions	43
scope of supply.....	21	Transducer	
supply power		description	17
requirements.....	27, 38		
supply voltage			
display	38	U	
Hull Unit	40	uninterruptible power supply	
Operating Panel (Mk1).....	38	description	21
Operating Panel (Mk2).....	39	required item	21
Operating Panel (Mk3).....	39	requirements.....	27
requirements.....	27	scope of supply.....	21
transceiver	39	UPS	
Transceiver Unit	39	description	21
support		required item	21
information	30	requirements.....	27
offices.....	30	scope of supply.....	21
Support information	30		
SX92 hull unit		W	
dimensions.....	80	weight	
SX93 hull unit		computer	41
dimensions.....	83	display	41
SX95 hull unit		Hull Unit	43
dimensions.....	86	Operating Panel (Mk1).....	42
system		Operating Panel (Mk2).....	42
description	10	Operating Panel (Mk3).....	42
diagram.....	12	Processor Unit.....	41
		transceiver	43
		Transceiver Unit	43
		weight	
		technical specifications.....	41
		wiring	
		requirements.....	28
		Y	
		yyy.....	39
T			
technical requirements			
ac mains power.....	38		
mains power	38		
power	38		
supply power	38		
technical specification			
environmental requirements.....	45		
technical specifications			
compass safe distance	48		
introduction	34		
performance	34		
technical specifications			
outline dimensions.....	41		
weight	41		
technical support			
information	30		
offices.....	30		
transceiver			
Compass Safe Distance (CSD).....	49		
environmental requirements.....	47		
outline dimensions.....	43		
power consumption.....	39		
power requirements.....	39		
weight	43		
Transceiver Unit			
Compass Safe Distance (CSD).....	49		
description	15		
environmental requirements.....	47		

©2023 Kongsberg Maritime
ISBN N/A



KONGSBERG

KONGSBERG MARITIME
SIMRAD
Strandpromenaden 50
P.O. Box 111
kongsberg.com/simrad

Switchboard: +47 815 73 700

E-mail sales: simrad.sales@simrad.com
E-mail support: simrad.support@simrad.com



kongsberg.com/simrad